

# *TOSVERT VF-AS3*

## PID control Instruction Manual

Introduction	1
PID control selection	2
Parameter list of PID control	3
Setting for PID control	4
PID control adjustment	5
Analog input characteristics	6
PID2 control	7
Parameter list of PID2 control	8
External PID control	9
Parameter list of external PID control	10

**TOSHIBA INDUSTRIAL PRODUCTS AND SYSTEMS CORPORATION**

### NOTICE

1. Read this manual before installing or operating the inverter. Keep it in a safe place for reference.
2. All information contained in this manual will be changed without notice.



## Contents

1	Introduction .....	1-1
2	PID control selection .....	2-1
2.1	Process PID control .....	2-1
2.2	Speed PID control .....	2-3
2.3	Easy positioning PID control .....	2-5
2.4	Dancer control .....	2-8
3	Parameter list of PID control .....	3-1
4	Setting for PID control .....	4-1
4.1	Fundamental setting .....	4-1
4.1.1	Feedback value .....	4-1
4.1.2	Set value .....	4-4
4.1.3	Override function .....	4-8
4.1.4	Acceleration and deceleration time .....	4-9
4.2	Set to suit the motor .....	4-9
4.3	Set to suit the system .....	4-10
4.3.1	Set if necessary .....	4-10
4.3.2	Switch PID characteristics .....	4-10
4.3.3	Agreement between set value and feedback value .....	4-11
4.3.4	Switch to frequency command operation .....	4-11
4.3.5	Deviation limit of PID control .....	4-11
5	PID control adjustment .....	5-1
5.1	Summary of adjustment .....	5-1
5.2	Fundamental adjustment (common) .....	5-1
5.2.1	Proportional (P) gain .....	5-2
5.2.2	Integral (I) gain .....	5-2
5.2.3	Differential (D) gain .....	5-2
5.3	Applied adjustment (Common) .....	5-3
5.3.1	PID integral / differential reset .....	5-3
5.3.2	PID control wait time .....	5-3
5.4	Applied adjustment (for speed PID control) .....	5-3
5.4.1	Delay filter .....	5-3
5.4.2	Set value increase time, decrease time .....	5-4
6	Analog input characteristics .....	6-1
7	PID2 control .....	7-1
8	Parameter list of PID2 control .....	8-1
9	External PID control .....	9-1
10	Parameter list of external PID control .....	10-1



# 1

## Introduction

VF-AS3 has four types of PID control function. You can select the type for your application.

- Process PID control: For temperature or pressure control of fan and pump, which is performed relatively gently in response to change the speed.
- Speed PID control: For speed control of machinery such as a winder, which is performed at high speed in response to change the speed.
- Easy positioning PID control: For stop position control
- Dancer control: For dancer control of winder system

Additionally, "PID2 control" that controls PID optimally by switching between two different set values and feedback values, and "External PID control" that outputs calculation results of PID control as numerical values or analog values to allow the external equipment to use the inverter like a PID controller are provided.

This manual is constructed as follows;

- Chapter 2: Explanation of four types of PID control
- Chapter 3: Parameter list for PID control
- Chapter 4: Setting parameters for PID control
- Chapter 5: Adjustment for PID control
- Chapter 6: Analog input characteristics  
For PID control and PID 2 control, it is necessary to convert set value and feedback value into frequency for setting.
- Chapter 7: Explanation of PID 2 control
- Chapter 8: Parameter list for PID 2 control
- Chapter 9: Explanation of external PID control
- Chapter 10: Parameter list for external PID control

1

2

3

4

5

6

7

8

9

10



# 2 | PID control selection

Select one from the four types of PID control function for your application.

## 2.1 Process PID control

Process PID control is selected for temperature or pressure control of fan and pump which is performed gently in response to change the speed.

**[F359: PID control1]** = "1: Process PID control" (Plus characteristic)  
 = "11: Minus Process PID control"

### ■ Diagram

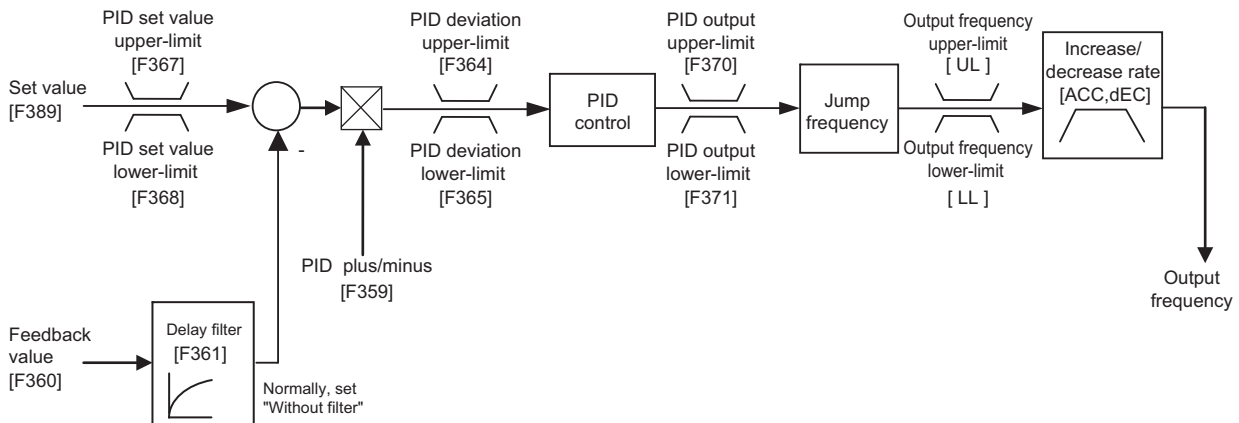

### ■ Parameter setting

Refer to chapter 4 and 5 for detail of parameter setting.

#### 1) Select the input of set value and feedback value.

It is necessary to convert temperature or pressure into frequency for setting.

Item	Title	Parameter name
Set value	F389	PID1 set value select
	FPId	PID1 set value (Only [F389]="12")
Feedback value	F360	PID1 feedback input select

Frequency free unit conversion function enables to set the set value and the feedback value easily. Refer to chapter 3 for detail.



**2) Set the following parameters to suit the motor if necessary.**

Title	Parameter name
FH	Maximum frequency
UL	Upper limit frequency
LL	Lower limit frequency
F270 to F275	Jump frequency 1 to 3
F240	Start frequency
F241	Run frequency
F243	End frequency

**3) Set the following parameters to suit the system.**

a) Set the acceleration time and deceleration time to short for quick response within the range not to cause inverter trip.

Title	Parameter name
ACC	Acceleration time1
dEC	Deceleration time1

b) Set the following parameters if necessary.

Item	Title	Parameter name
Limit the input level of set value.	F367	PID1 set value upper-limit
	F368	PID1 set value lower-limit
Limit the level of PID output.	F370	PID1 output upper-limit
	F371	PID1 output lower-limit
Switch the PID plus/minus characteristics.	F359	PID control1 (with selection of plus/minus) [F359]= "1" : Plus characteristic [F359]= "11" : Minus Process
		Input terminal function "54/55: PID plus/minus switching"
Output of agreement signal between set value and feedback value.	F374	PID1 set value agreement detection band
		Output terminal function "144/145: PID1,2 frequency command agreement"

**4) Adjust the PID control gain.**

Refer to chapter 5 for detail.

a) Fundamental adjustment

Item	Title	Parameter name
PID control gain	F362	PID1 proportional gain
	F363	PID1 integral gain
	F366	PID1 differential gain



b) Adjust the following parameter if necessary.

Item	Title	Parameter name
Steady the PID control. (Limit the PID deviation*1)	F364	PID1 deviation upper-limit
	F365	PID1 deviation lower-limit
Start the PID control after the system becomes stable.	F369	PID control start wait time

\*1 Deviation means difference between the set value and the feedback value.

## 2.2 Speed PID control

Speed PID control is selected for speed control of a winder to which fast response is required. Acceleration/ deceleration time is automatically set to the shortest time. It also responds much faster by controlling with the increase/ decrease rate which is separated from acceleration/ deceleration time. Delay filter is set to the feedback value for the stable operation.

**[F359: PID control1] = "2: Speed PID control" (Plus characteristic)**  
**= "12: Minus Speed PID control"**

■ Diagram

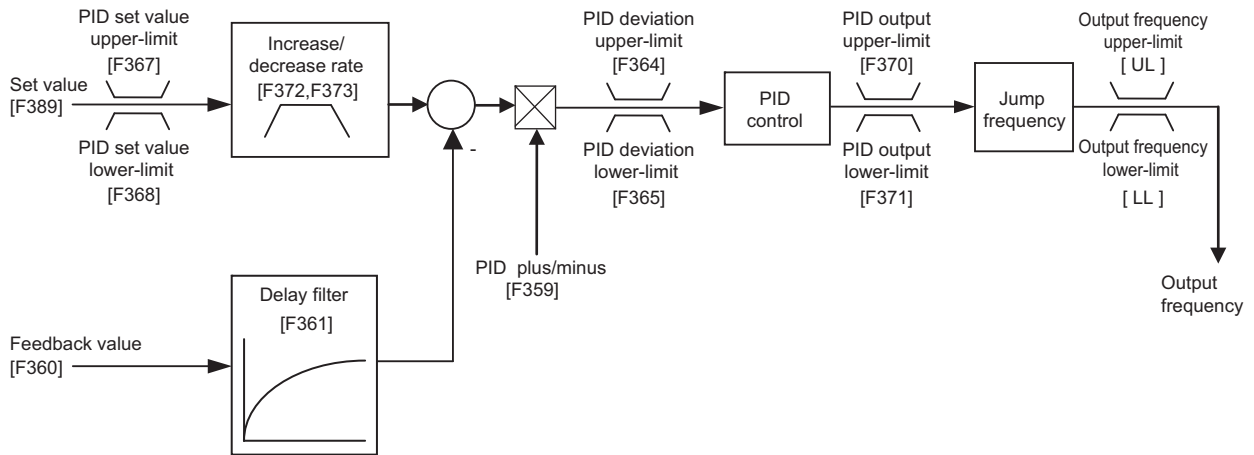

■ Parameter setting

Refer to chapter 4 and 5 for detail of parameter setting.

1) Select the input of set value and feedback value.

It is necessary to convert tension level into frequency for setting.

Item	Title	Parameter name
Set value	F389	PID1 set value select
	FPId	PID1 set value (Only [F389]="12")
Feedback value	F360	PID1 feedback input select

- a) Frequency free unit conversion function enables to set the set value and the feedback value easily. Refer to chapter 3 for detail.
- b) It is possible to add or multiply for set value by override function.

Item	Title	Parameter name
Addition	F660	Override adding input select
Multiplication	F661	Override multiplying input select

**2) Set the following parameters to suit the motor if necessary.**

Title	Parameter name
FH	Maximum frequency
UL	Upper limit frequency
LL	Lower limit frequency
F270 to F275	Jump frequency 1 to 3
F240	Start frequency
F241	Run frequency
F243	End frequency

**3) Set the following parameters to suit the system.**

Speed PID control set the acceleration time and the deceleration time to the smallest automatically regardless of parameter ([ACC], [dEC]) setting.

Set the following parameters if necessary.

Item	Title	Parameter name
Limit the input level of set value.	F367	PID1 set value upper-limit
	F368	PID1 set value lower-limit
Limit the level of PID output.	F370	PID1 output upper-limit
	F371	PID1 output lower-limit
Output of agreement signal between set value and feedback value.	F374	PID1 set value agreement detection band
		Output terminal function "144/145: PID1,2 frequency command agreement "

**4) Adjust the PID control gain.**

Refer to chapter 5 for detail.

- a) For fundamental adjustment.

Item	Title	Parameter name
PID control gain	F362	PID1 proportional gain
	F363	PID1 integral gain
	F366	PID1 differential gain

b) Adjust for stability, and quick response.

Item	Title	Parameter name
Steady the PID control (Feedback filter)	F361	PID1 filter
Steady the PID control. (Limit the PID deviation*1)	F364	PID1 deviation upper-limit
	F365	PID1 deviation lower-limit
Adjust for quick response	F372	PID1 set value increase time
	F373	PID1 set value decrease time
Start the PID control after the system becomes stable.	F369	PID control start wait time

\*1 Deviation means difference between the set value and the feedback value.

## 2.3 Easy positioning PID control

Easy positioning PID control is selected to retain the stop position in the vector control with speed sensor. When [Pt: V/f Pattern] = "10" or "11", the easy positioning control is entered with the input terminal assigned [72: Simple positioning] turned on, considering the point as zero positional deviation. When the PG input pulse number is within the setting value of [F381: Simple positioning completion range] during the easy positioning control, a signal can be output from the output terminal to which [118: Stop positioning completion] is assigned.

**[F359: PID control1] = "3: Easy positioning PID control" (Plus characteristic)**  
**= "13: Minus Easy positioning PID control"**

■ Diagram

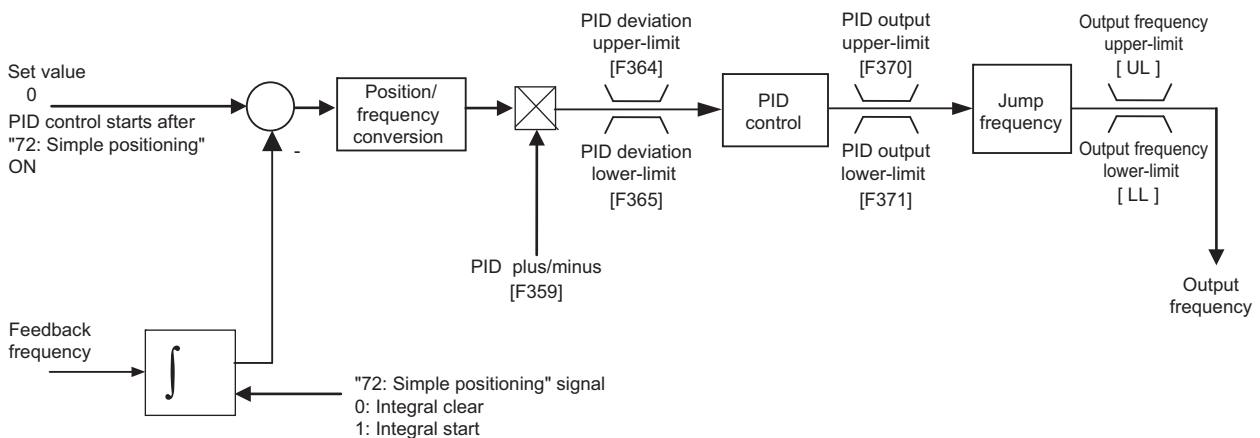

\* While the [72: Simple positioning] signal is not input, the PID control is not executed. When the simple positioning signal is input, the PID control is executed so that a stop occurs at the position at which the signal is input.

■ **Parameter setting**

Refer to chapter 4 and 5 for detail of parameter setting.

**1) Set parameters of PG after [Pt]= "10" or "11" setting. Set [240],[F241],[F243] = "0.0(Hz)".**

Title	Parameter name
Pt	V/f Pattern
F375	PG pulses number
F376	PG select
F377	PG option disconnection detection
F379	PG option voltage
F240	Start frequency
F241	Run frequency
F243	End frequency

Note 1) Set [240], [F241], [F243] = "0.0(Hz)". If the setting value is different, a 0Hz command cannot be output, resulting in incorrect operation of the easy positioning PID control.

Set value and feedback value are below. (not select)

Item	Function
Set value	0 (pulse)
Feedback value	Current position (Pulse number from the set value)

**2) Set the following parameters to suit the motor if necessary.**

Title	Parameter name
FH	Maximum frequency
UL	Upper limit frequency
LL	Lower limit frequency

**3) Set the following parameters to suit the system.**

Item	Title	Parameter name
Limit the level of PID output.	F370	PID1 output upper-limit
	F371	PID1 output lower-limit
Output of agreement signal between set value and feedback value.	F381	Simple positioning completion range
		Output terminal function "118/119: Stop positioning completion"

#### 4) Adjust the PID control gain.

Refer to chapter 5 for detail.

a) For fundamental adjustment.

Item	Title	Parameter name
PID control gain	F362	PID1 proportional gain
	F363	PID1 integral gain
	F366	PID1 differential gain

b) Adjust the following parameter if necessary.

Item	Title	Parameter name
Steady the PID control. (Limit the PID deviation*1)	F364	PID1 deviation upper-limit
	F365	PID1 deviation lower-limit

\* The deviation is a current position converted into a frequency which is obtained by the following formula.

$$\text{Deviation} = \frac{\text{Current position (pulse)} \times \text{Number of motor poles}}{[\text{F375: PG pulse number}]}$$

#### ■ Operation sample

Use this for positioning of machinery, etc. Decelerate from a top speed and operate at a creep speed around the set position. When the set position is reached and the [72: Simple positioning] signal is turned on, machinery reciprocates around the set position and finally stops at the set position.

Note 1) Executing the stop position retaining control with high-speed operation may cause an over current trip, overvoltage trip, etc. Pass on to low-speed operation and then turn on the simple positioning signal.

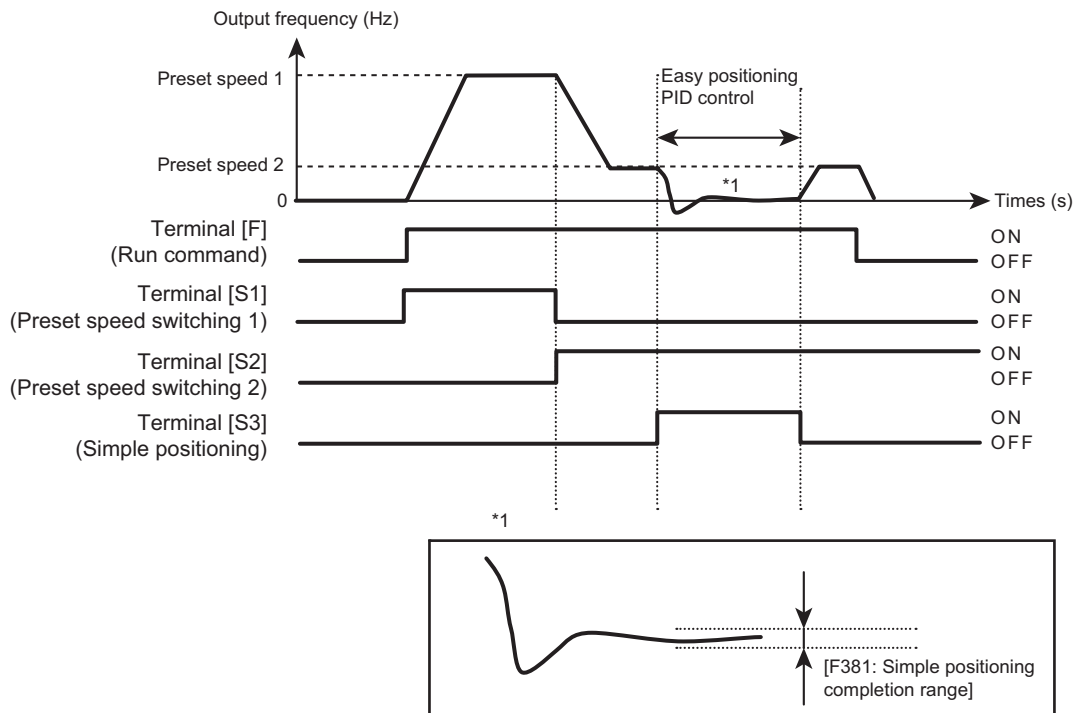

■ **Trouble shooting**

If an overvoltage trip occurs during deceleration of the stop position retaining control, make the value of [F362: PID1 proportional gain] smaller. The deceleration time will become longer.

Note 1 [dEC: Deceleration time 1] setting is invalid during easy positioning PID control.

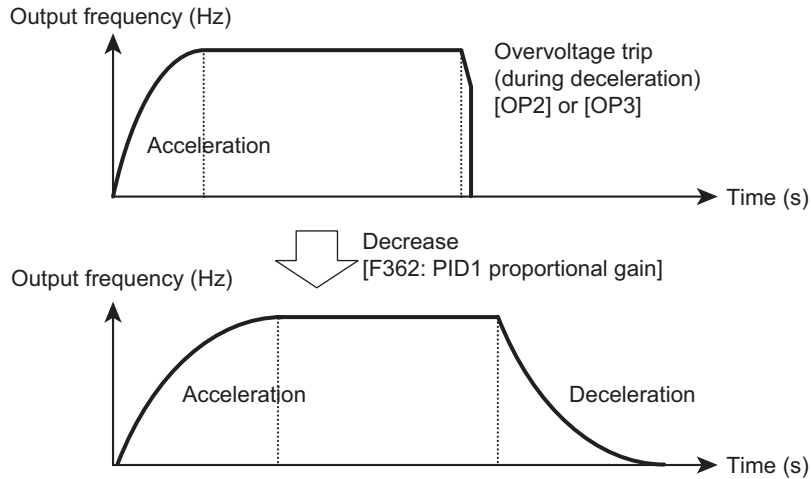

## 2.4 Dancer control

Dancer control is selected for dancer positioning control of winder system.

[F359: PID control1] = "4: Dancer control" (Plus characteristic)  
 = "14: Minus Dancer control"

■ **System image**

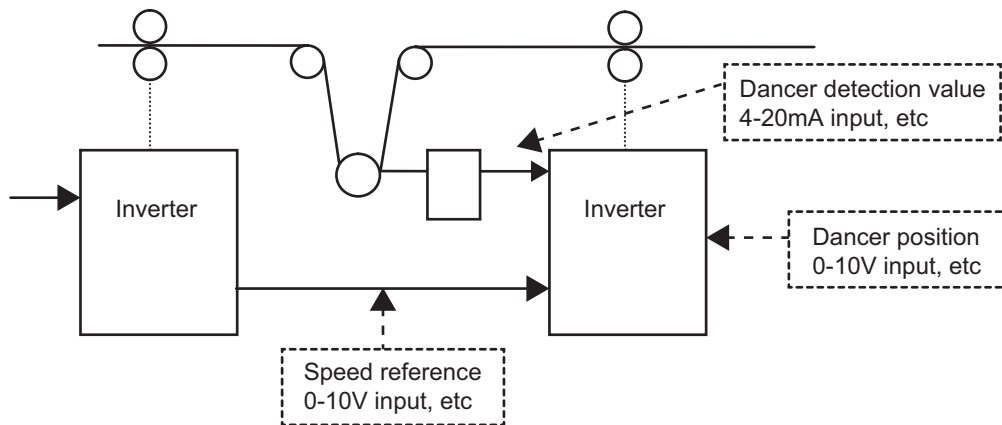

■ Diagram

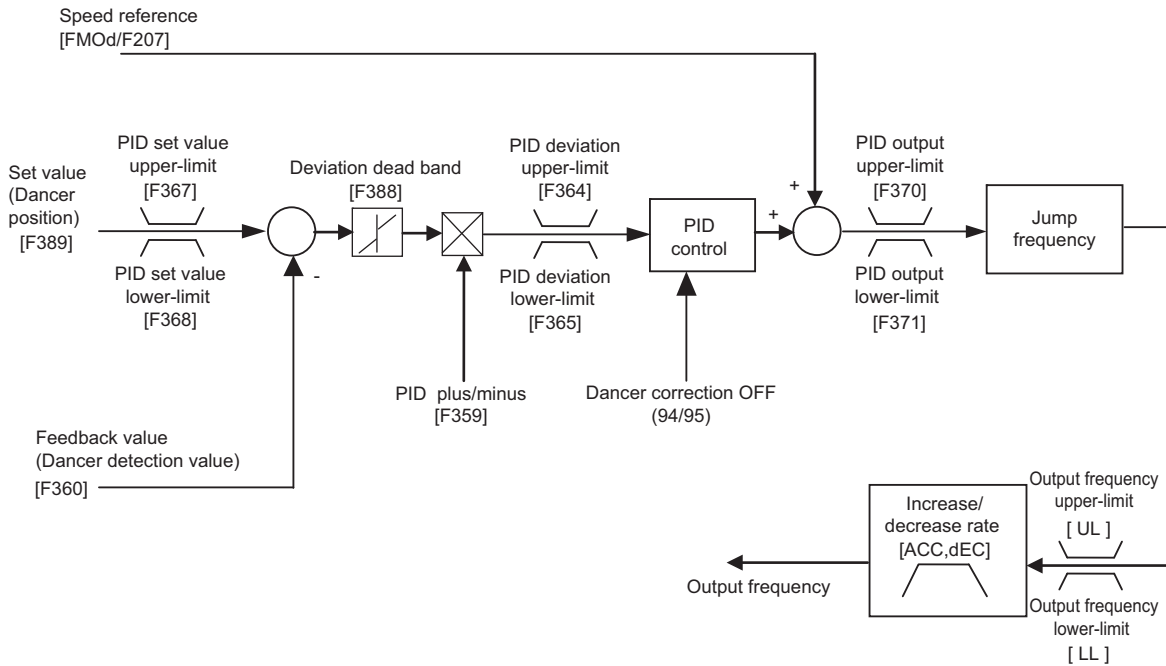

2

■ Dancer control operation

- 1) Inverter operates by speed reference.
- 2) PID control: Set value: dancer position  
Feedback value: dancer detection value  
Correct speed reference by deviation of PID control for dancer.  
Set the dead band for the deviation if necessary.
- 3) When you don't need dancer correction, turn the input terminal assigned "36: PID control OFF" ON.  
In case the input terminal ON, the PID output is zero. The inverter operates by frequency command.
- 4) To keep the current value of dancer correction frequency, turn on the input terminal to which [94: Dancer correction OFF] is assigned.  
In this case, the PID output is kept the value at which the dancer correction OFF signal is input.

■ Parameter setting

Refer to chapter 4 and 5 for detail of parameter setting.

- 1) Select the input of dancer position (set value) and dancer detection value (feedback value).  
Set each level converted into frequency for the setting.  
Set the dead band for deviation between set value and feedback value if necessary.

Item	Title	Parameter name
Speed reference	FMOd	Frequency command select 1
	F207	Frequency command select 2
Feedback value	F360	PID1 feedback input select
PID output dead band	F388	PID1 output dead band

Frequency free unit conversion function enables to set the set value and the feedback value easily. Refer to chapter 3 for detail.

**2) Set the following parameters to suit the winder system if necessary.**

Item	Title	Parameter name
Operation by speed reference only (Dancer correction OFF)	Input terminal function "94/95: Dancer correction OFF"	
Inhibit the reverse-run	F311	Reverse inhibited

2

**3) Set the following parameters to suit the motor if necessary.**

Title	Parameter name
FH	Maximum frequency
UL	Upper limit frequency
LL	Lower limit frequency
F270 to F275	Jump frequency 1 to 3
F240	Start frequency
F241	Run frequency
F243	End frequency

**4) Set the following parameters to suit the system.**

a) Set the acceleration time and deceleration time to short for quick response within the range not to cause inverter trip.

Title	Parameter name
ACC	Acceleration time 1
dEC	Deceleration time 1

b) Set the following parameters if necessary.

Item	Title	Parameter name
Limit the input level of set value.	F367	PID1 set value upper-limit
	F368	PID1 set value lower-limit
Limit the level of PID output.	F370	PID1 output upper-limit
	F371	PID1 output lower-limit
Switch the PID plus/minus characteristics.	F359	PID control1 (with selection of plus/minus) [F359]= "4": Plus characteristic [F359]= "14": Minus characteristic
	Input terminal function "54/55: PID plus/minus switching"	
Output of agreement signal between set value and feedback value.	F374	PID1 set value agreement detection band
	Output terminal function "144/145: PID1,2 frequency command agreement"	

**5) Adjust the PID control gain.**

Refer to chapter 5 for detail.

a) Fundamental adjustment



Item	Title	Parameter name
PID control gain	F362	PID1 proportional gain
	F363	PID1 integral gain
	F366	PID1 differential gain

b) Adjust the following parameter if necessary.

Item	Title	Parameter name
Steady the PID control. (Limit the PID deviation*1)	F364	PID1 deviation upper-limit
	F365	PID1 deviation lower-limit
Start the PID control after the system becomes stable.	F369	PID control start wait time

\*1 Deviation means difference between the set value and the feedback value.



# 3

## Parameter list of PID control

Title	Parameter name	Adjustment range	Default setting
FMOd	Frequency command select 1	0: - 1: Terminal RR 2: Terminal RX 3: Terminal II 4: Terminal AI4 (option) 5: Terminal AI5 (option) 6 - 9: - 10: Touch wheel 1 (power off or press OK to save) 11: Touch wheel 2 (press OK to save) 12: Sr0 13,14: - 15: Terminal Up/Down frequency 16: Pulse train 17: High resolution pulse train (option) 18,19: - 20: Embedded Ethernet 21: RS485 communication (connector 1) 22: RS485 communication (connector 2) 23: Communication option	1
FH	Maximum frequency	30.0 - 590.0 (Hz)	*1
UL	Upper limit frequency	0.0 - FH (Hz)	50.0/ 60.0 *1
LL	Lower limit frequency	0.0 - UL (Hz)	0.0
ACC	Acceleration time 1	0.0 - 6000 (s)	10.0 *1
dEC	Deceleration time 1	0.0 - 6000 (s)	10.0 *1
Sr0 toSr7	Preset speed 0 to 7	LL - UL (Hz)	0.0
FPId	PID1set value	F368 - F367 (Hz)	0.0
F201	RR point 1 input value	0 - 100 (%)	0
F202	RR point 1 frequency	0.0 - 590.0 (Hz)	0.0
F203	RR point 2 input value	0 - 100 (%)	100
F204	RR point 2 frequency	0.0 - 590.0 (Hz)	50.0/ 60.0 *1
F207	Frequency command select 2	Same as FMOd	3
F210	RX point 1 input value	-100 to +100 (%)	0
F211	RX point 1 frequency	0.0 - 590.0 (Hz)	0.0
F212	RX point 2 input value	-100 to +100 (%)	100
F213	RX point 2 frequency	0.0 - 590.0 (Hz)	50.0/ 60.0 *1
F216	II point 1 input value	0 - 100 (%)	20
F217	II point 1 frequency	0.0 - 590.0 (Hz)	0.0



Title	Parameter name	Adjustment range	Default setting
F218	II point 2 input value	0 - 100 (%)	100
F219	II point 2 frequency	0.0 - 590.0 (Hz)	50.0/ 60.0*1
F240	Start frequency	0.0 - 10.0 (Hz)	0.1
F241	Run frequency	0.0 - FH (Hz)	0.0
F243	End frequency	0.0 - 30.0(Hz)	0.0
F270	Jump frequency1	0.0 - FH (Hz)	0.0
F271	Jump frequency 1 band	0.0 - 30.0(Hz)	0.0
F272	Jump frequency2	0.0 - FH (Hz)	0.0
F273	Jump frequency 2 band	0.0 - 30.0(Hz)	0.0
F274	Jump frequency3	0.0 - FH (Hz)	0.0
F275	Jump frequency 3 band	0.0 - 30.0(Hz)	0.0
F311	Reverse inhibited	0 - 4	0
F359	PID control1	0: Disabled 1: Process PID control 2: Speed PID control 3: Easy positioning PID control 4: Dancer control 5 - 10: - 11: Minus Process PID control 12: Minus Speed PID control 13: Minus Easy positioning PID control 14: Minus Dancer control	0
F360	PID1 feedback input select	0: - 1: Terminal RR 2: Terminal RX 3: Terminal II 4: Terminal AI4 (option) 5: Terminal AI5 (option) 6 - 16: - 17: High resolution pulse train (option)	0
F361	PID1 filter	0.0 - 25.0 (s)	0.0
F362	PID1 proportional gain	0.01 - 100.0	0.30
F363	PID1 integral gain	0.01 - 100.0 (s <sup>-1</sup> )	0.20
F364	PID1 deviation upper-limit	LL - UL (Hz)	50.0/ 60.0*1
F365	PID1 deviation lower-limit	LL - UL (Hz)	50.0/ 60.0*1
F366	PID1 differential gain	0.00 - 2.55 (s)	0.00
F367	PID1 set value upper-limit	0.0- FH(Hz)	50.0/ 60.0*1
F368	PID1 set value lower-limit	0.0- F367(Hz)	0.0
F369	PID control start wait time	0 - 2400 (s)	0
F370	PID1 output upper-limit	LL - UL (Hz)	50.0/ 60.0*1
F371	PID1 output lower-limit	LL - UL (Hz)	0.0

Title	Parameter name	Adjustment range	Default setting
F372	PID1 set value increase time	0.1 - 600.0 (s)(Speed PID)	10.0
F373	PID1 set value decrease time	0.1 - 600.0 (s)(Speed PID)	10.0
F374	PID1 set value agreement detection band	0.0 - FH (Hz)	2.5
F375	PG pulses number	1 - 9999 (pulse)	1000
F376	PG select	0: PTI (Command) - PTI (FB) 1: PTI (Command) - Digital option (FB) 2 - 5: - 6: Digital option (Command) - Non FB 7 - 9: - 10: PTI (Command) - PTI (FB inversion) 11: PTI (Command) - Digital option (FB inversion) 12 - 15: - 16: Digital option (Command inversion) - Non FB	0
F377	PG option disconnection detection	0: Disabled 1: Enabled	0
F379	PG option voltage	0: 5V 1: 12V 2: 24V	0
F381	Simple positioning completion range	1 - 4000 (pulse)	100
F388	PID1 output dead band	0 - 100 (%)	0
F389	PID1 set value select	0: selected by FMOd/F207 1: Terminal RR 2: Terminal RX 3: Terminal II 4: Terminal AI4 (option) 5: Terminal AI5 (option) 6 - 11:- 12: FPId 13,14: - 15: Terminal Up/Down frequency 16: Pulse train 17: High resolution pulse train (option) 18,19: - 20: Embedded Ethernet 21: RS485 communication (connector 1) 22: RS485 communication (connector 2) 23: Communication option	0

Title	Parameter name	Adjustment range	Default setting
F660	Override adding input select	0: - 1: Terminal RR 2: Terminal RX 3: Terminal II 4: Terminal AI4 (option) 5: Terminal AI5 (option) 6 - 9: - 10: Touch wheel 1 (power off or press OK to save) 11 - 14: - 15: Terminal Up/Down frequency 16: Pulse train 17: High resolution pulse train (option) 18,19: - 20: Embedded Ethernet 21: RS485 communication (connector 1) 22: RS485 communication (connector 2) 23: Communication option	0
F661	Override multiplying input select	0: - 1: Terminal RR 2: Terminal RX 3: Terminal II 4: Terminal AI4 (option) 5 - 11: - 12: F729 13 - 23: -	0
F702	Free unit multiplication factor	0.00: Disabled 0.01 - 200.0 (times)	0.00
F703	Target of free unit	0: All frequencies 1: PID frequencies	0
F729	Panel override multiplication gain	-100 to +100 (%)	0

\*1: Depending on the setup menu.

### Input /Output terminal function

Terminal	Positive logic	Negative logic	Function
Input terminal	36	37	PID control OFF
	52	53	PID differential/integral reset
	54	55	PID plus/minus switching
	72	73	Simple positioning
	94	95	Dancer correction OFF
Output terminal	38	39	PID deviation limit
	118	119	Stop positioning completion
	144	145	PID1,2 frequency command agreement

## FM/AM/pulse output and monitor output function

FM/AM/Pulse output		Monitor output		Function
Set No.	Communication No.	Set No.	Communication No.	
1	FD02	1	FE02	Frequency command value (set value)
13	FD22	13	FE22	PID feedback value
62	FD48	62	FE48	PID result frequency
63	FD58	63	FE58	PID set value

■ **Unit conversion (Free unit conversion)**

You need to convert the set value and the feedback value into frequency for the PID control. [F702: Free unit multiplication factor] and [F703: Target of free unit] enable to set the set value and the feedback value easily. The functions convert frequency display to temperature or pressure level by calculation.

**Value displayed = Frequency displayed on the monitor or specified with a parameter × [F702]**

● **When [F703] = "0"**

Frequency on the monitor or specified with parameter is displayed by the value multiplied by [F702].

Note1) This setting does not change automatically when you switch from PID control to frequency command operation. Output frequency is displayed by the value by [F702].

● **When [F703] = "1"**

Frequency of the following parameters and the frequency on the monitor are displayed by the value multiplied by [F702].

**Parameter**

Title	Parameter name
FPId	PID1 set value
F364	PID1 deviation upper-limit
F365	PID1 deviation lower-limit
F367	PID1 set value upper-limit
F368	PID1 set value lower-limit
F374	PID1 set value agreement detection band

**FM/AM/pulse output and monitor output function**

FM/AM/Pulse output		Monitor output		Function
Set No.	Communication No.	Set No.	Communication No.	
1	FD02	1	FE02	Frequency command value (set value)
13	FD22	13	FE22	PID feedback value
63	FD58	63	FE58	PID set value



# 4

## Setting for PID control

First, set the set value and the feedback value. : 4.1  
Then, set other parameters to suit the motor and the system if necessary. : 4.2, 4.3

Note) Set the set value and the feedback value by converting each pressure level into frequency. Actual output frequency is different from setting frequency for PID control.

### 4.1 Fundamental setting

Make sure to set the set value and the feedback value.

In case of process type PID control, you need to set acceleration time and deceleration time to short for quick response.

#### 4.1.1 Feedback value

Input the signal from detector as feedback signal.

##### (1) Select the input of feedback signal

Title	Parameter name	Adjustment range (input of feedback)
F360	PID feedback input select	0: - 1: Terminal RR 2: Terminal RX 3: Terminal II 4: Terminal AI4 (option) 5: Terminal AI5 (option) 6 - 16: - 17: High resolution pulse train (option)

Note) It is necessary I/O extension option "ETB013Z" for using terminals [AI4] and [AI5], digital encoder "VEC008Z" for using high resolution pulse train.

##### (2) Set feedback value after converting the feedback input level into frequency.

###### 1) Analog input

Refer to chapter 6 for detail of analog input characteristic setting.

###### Example of feedback setting

Condition: Pressure control as PID control.

Input the feedback signal of 1 to 2 atm into terminal [II] by 4 to 20mA signal.

[F360]= "3: terminal II"

Convert input level 4-20mA by terminal [II] to 0-60Hz.

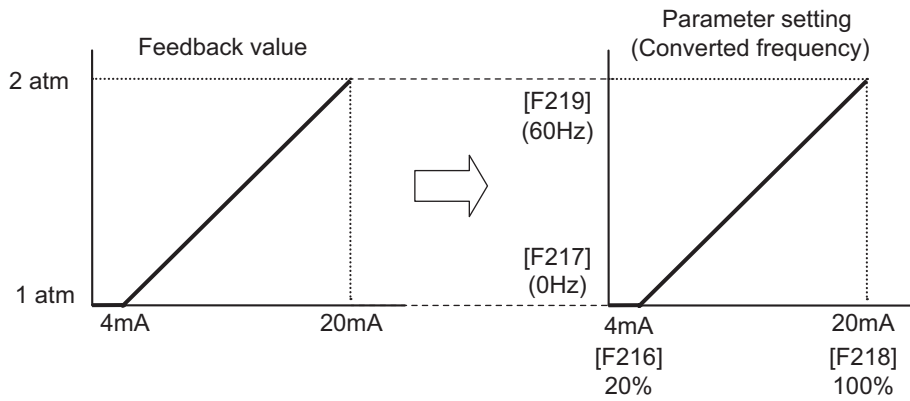

It is possible to set or switch the plus/minus characteristics.

• **When setting minus characteristic**

Select minus characteristic by [F359].

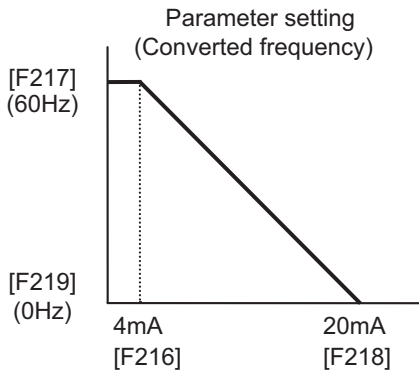

• **When switching characteristic by terminal [S3] (positive logic)**

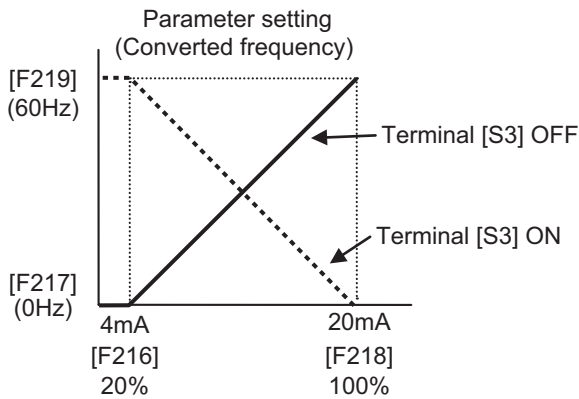

\* When switching the characteristics using terminals, not only characteristics of set value but also of feedback value switches.

Title	Parameter	Example of setting
F116	Terminal S3 function	54: PID plus/minus switching (positive logic)
F216	II point 1 input value	20 (%)
F217	II point 1 frequency	0 (Hz)
F218	II point 2 input value	100 (%)
F219	II point 2 frequency	60 (Hz)

The characteristics is plus when selecting minus characteristics both [F359] setting and input terminal,

## 2) Optional terminal input

You can input the signal into optional terminals [AI4] and [AI5] as same as analog input. Refer to chapter 6 for detail of input characteristic setting.

## 3) PG feedback input

It is used in speed PID control mainly.

Set [Pt: V/f pattern] to except "10: PG feedback control" or "11: PG feedback vector control".

### Example of feedback value setting

Calculate the input pulse frequency to percent base data by the following. Set the parameters of 2 input points.

$$\text{Percent base data} = \frac{\text{Input pulse frequency} \times 100(\%)}{\text{PG input pulse} \times \text{Maximum frequency}}$$

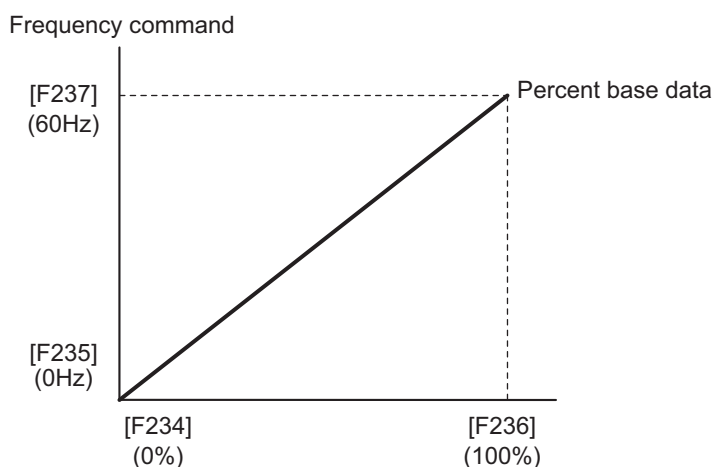

Title	Parameter name	Adjustment range	Example of setting
FH	Maximum frequency	30.0 - 590.0	60(Hz)
F234	Pulse train input point 1 input value	0 - 100	0(%)
F235	Pulse train input point 1 frequency	0.0 - 590.0	0(Hz)
F236	Pulse train input point 2input value	0 - 100	100(%)
F237	Pulse train input point 2 frequency	0.0 - 590.0	60(Hz)
F375	PG pulses number	1 - 9999	1000

Title	Parameter name	Adjustment range	Example of setting
F376	PG select	0: PTI (Command) - PTI (FB) 1: PTI (Command) - Digital option (FB) 2 - 5: - 6: Digital option (Command) - Non FB 7 - 9: - 10: PTI (Command) - PTI (FB inversion) 11: PTI (Command) - Digital option (FB inversion) 12 - 15: - 16: Digital option (Command inversion) - Non FB	6
F377	PG option disconnection detection	0: Disabled 1: Enabled	1
F379	PG option voltage	0: 5V 1: 12V 2: 24V	0

Note 1) In case of using shaft built-in type PG, set the pulse train input point 2 to a multiple number of "1/(a half number of motor poles)".  
For example, set [F236]="50(%)" when using shaft built-in type PG with 4-poles motor.

## 4. 1. 2 Set value

Input the target value in relation to the feedback value as set value.

### (1) Select the input of set value

Title	Parameter name	Adjustment range (input of set value)
F389	PID1 set value select	0: selected by FMOd/F207 1: Terminal RR 2: Terminal RX 3: Terminal II 4: Terminal AI4 (option) 5: Terminal AI5 (option) 6 - 11: - 12: FPId 13,14: - 15: Terminal Up/Down frequency 16: Pulse train 17: High resolution pulse train (option) 18,19: - 20: Embedded Ethernet 21: RS485 communication (connector 1) 22: RS485 communication (connector 2) 23: Communication option

It is possible to add or multiply for process value by override function.

(2) Convert the set value to frequency.



Input the set value to maximum of the feedback value or less.  
 If the set value is same as maximum of the feedback value, the deviation becomes zero when the feedback value reaches maximum. The output frequency is fixed even though actual output becomes even higher, because the feedback value will not exceed maximum.  
 Upper limit of set value can be set by parameter [F367: PID1 set value upper-limit].

1) When setting set value to [FPId]

**Example of set value setting**

Set [F389]= "12: FPId".

Convert the target of the pressure value to frequency as set value, and then set it to [FPId].

Example: [FPId]= "30(Hz)" when the target is 1.5 atm.

Input the feedback signal of 1 to 2 atm into terminal [II] by 4 to 20mA signal. Convert the input level 4-20mA by terminal [II] to 0-60Hz.

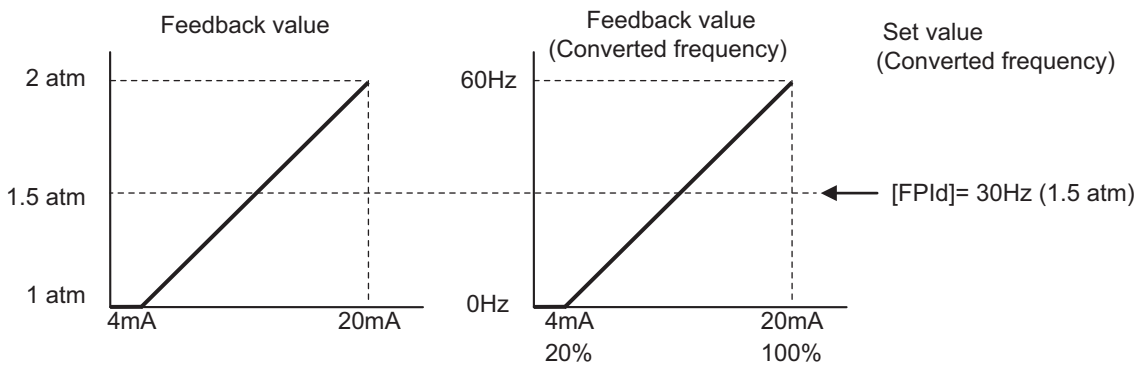

**Example of parameter setting**

Title	Parameter name	Example of setting
FPId	PID1 set value	30 (Hz)
F216	II point 1 input value	20 (%)
F217	II point 1 frequency	0 (Hz)
F218	II point 2 input value	100 (%)
F219	II point 2 frequency	60 (Hz)
F360	PID1 feedback input select	3: Terminal II
F389	PID1 set value select	12: FPId

Note 1) Value of [FPId] can be set or changed during operation with the use of touch wheel in [Standard mode], and then saved in [FPId].

Note 2) Input the set value to maximum of the feedback value or less.

## 2) Analog input

Refer to chapter 6 for detail of analog input characteristic setting.

### Example of set value setting

Input the set value to terminal [RX] by 0 to 10V.

Input the feedback signal of 1 to 2 atm into terminal [II] by 4 to 20mA signal. Convert the input level 4-20mA by terminal [II] to 0-60Hz.

### Example of system

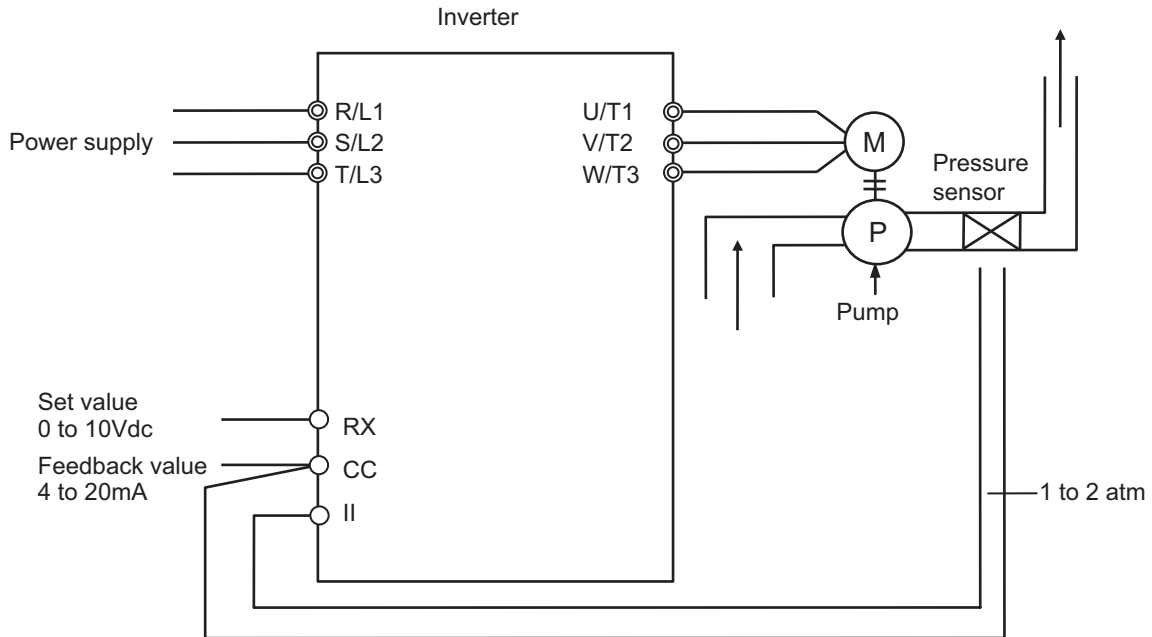

### Parameter setting

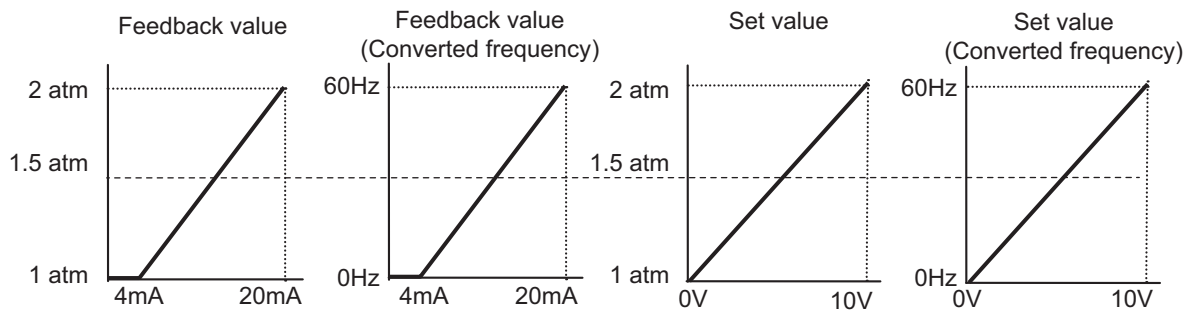

Pressure (atm)	Feedback value (4 to 20mA)	Set value (0 to 10V)	Converted frequency (Hz)
1	4	0	0
1.25	8	2.5	15
1.5	12	5.0	30
1.75	16	7.5	45
2	20	10	60

Set [F389: PID1 set value select]= "2: Terminal RX".

Convert the input level of terminal [RX] into frequency by parameters [F210] to [F213].

Actual output frequency is, regardless of the converted frequency, the output frequency as a result of PID control.



Input the set value to maximum of the feedback value or less.  
 If the process value is 2 atm=10V (60Hz), the deviation becomes zero when the feedback value reaches 2 atm=20mA (60Hz). The output frequency is fixed even though actual output becomes even higher, because the feedback value will not exceed over 20mA (60Hz).

Title	Parameter name	Example of setting
F107	Terminal RX input voltage select	0: 0 to +10V
F210	RX point 1 input value	0(%)
F211	RX point 1 frequency	0(Hz)
F212	RX point 2 input value	100(%)
F213	RX point 2 frequency	60(Hz)
F216	II point 1 input value	20(%)
F217	II point 1 frequency	0(Hz)
F218	II point 2 input value	100(%)
F219	II point 2 frequency	60(Hz)
F360	PID1 feedback input select	3: Terminal II
F389	PID1 set value select	2: Terminal RX

### 3) Preset speed

#### Example of process value setting

Input the set value to terminal [S1] and [S2] by preset speed 1,2 and 3.  
 Input the feedback signal of 1 to 2 atm into terminal [II] by 4 to 20mA signal. Convert the input level 4-20mA by terminal [II] to 0-60Hz.

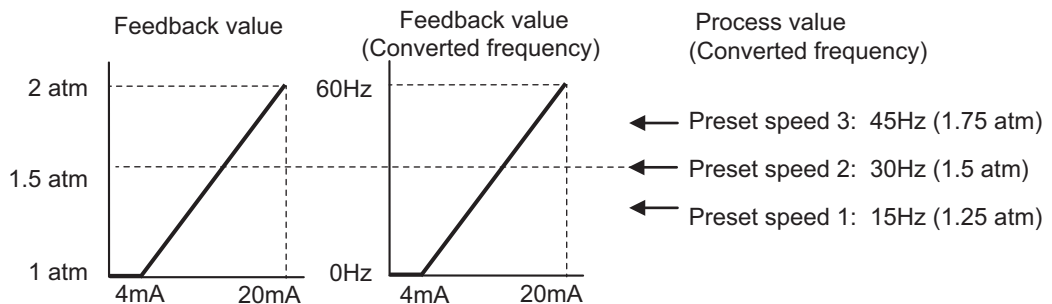

Pressure (atm)	Feedback value (4 to 20mA)	Set value			Converted frequency (Hz)
		Preset speed 1 to 3	Terminal [S1]	Terminal [S2]	
1	4	-	-	-	0
1.25	8	Speed 1	ON	OFF	15
1.5	12	Speed 2	OFF	ON	30
1.75	16	Speed 3	ON	ON	45
2	20	-	-	-	60

### Example of parameter setting

Title	Parameter name	Example of setting
Sr1	Preset speed 1	15(Hz)
Sr2	Preset speed 2	30(Hz)
Sr3	Preset speed 3	45(Hz)
F114	Terminal S1 function 1	10: Preset speed switching 1
F115	Terminal S2 function	12: Preset speed switching 2
F216	II point 1 input value	20(%)
F217	II point 1 frequency	0(Hz)
F218	II point 2 input value	100(%)
F219	II point 2 frequency	60(Hz)
F360	PID1 feedback input select	3: Terminal II

Note1) Input the set value to maximum of the feedback value or less.

## 4. 1. 3 Override function

### ■ Speed type

Override functions [F660], [F661] enable to add or multiply for fine adjustment of set value.

It is also possible to set multiplication gain by parameter [F729].

Refer to the inverter instruction manual for detail of the setting.

\* This function is also valid for process type PID, but it is rarely used.



## 4. 1. 4 Acceleration and deceleration time

- Process type
- Dancer control

Set the acceleration time [ACC] and deceleration time [dEC] to short for quick response.  
 But excessively small setting causes inverter trip.  
 Refer to 4.3.5 If you can not set acceleration and deceleration time to short.

- Speed type
- Easy positioning

Speed PID control and Easy positioning PID control set the acceleration time and the deceleration time to the smallest automatically regardless of parameter [ACC], [dEC] setting.

Note1) Adjust each gain in case that the inverter trips. If you need to extend acceleration time and the deceleration time, select the process type PID control.

## 4. 2 Set to suit the motor

Set only the parameters necessary for the motors.

These parameters are valid for actual output frequency as a result of PID control.

Title	Parameter name	Description
FH	Maximum frequency	<ul style="list-style-type: none"> <li>• Set the maximum frequency of the output frequency.</li> <li>• This is the basis of the acceleration time [ACC] and deceleration time [dEC].</li> </ul> Acceleration time [ACC]: time from 0Hz to [FH] Deceleration time [dEC]: time from [FH] to 0Hz
UL	Upper limit frequency	<ul style="list-style-type: none"> <li>• This is the upper limit of output frequency.</li> </ul>
LL	Lower limit frequency	<ul style="list-style-type: none"> <li>• This is the lower limit of output frequency.</li> </ul>
F240	Start frequency	<ul style="list-style-type: none"> <li>• The inverter outputs frequency of [F240] immediately.</li> <li>• It is useful for quick response of starting torque.</li> </ul>
F241	Run frequency	<ul style="list-style-type: none"> <li>• The inverter operates (Run/Stop) by [F241] setting frequency.</li> </ul>
F243	End frequency	<ul style="list-style-type: none"> <li>• The inverter decelerate then the output frequency is dropped to 0Hz at the frequency set by [F243].</li> </ul>
F270 to F275	Jump frequency 1 to 3	<ul style="list-style-type: none"> <li>• Set the jump frequency to avoid (jump) resonance of the machinery.</li> </ul>

Note 1) Note that the inverter may run and stop frequently when setting large value for [F241].

## 4.3 Set to suit the system

### 4.3.1 Set if necessary

Set the following parameters if necessary.

Title	Parameter name	Description
F367	PID1 set value upper-limit	<ul style="list-style-type: none"> <li>This is upper limit of set value.</li> <li>If the set value exceeds the upper limit of feedback value, the output frequency is fixed. (Refer to 4.2.1 for detail) Set the upper limit of set value when it is difficult to adjust by the input level of set value.</li> </ul>
F368	PID1 set value lower-limit	This is lower limit of set value.

4

### 4.3.2 Switch PID characteristics

You can set and switch the PID plus / minus characteristics.

It is useful for process type PID control including hot / cool switching of temperature control.

Title	Parameter name	Description
F359	PID control 1 (with selection of plus/minus)	You can select the PID plus / minus characteristics.

You can switch the characteristics of set value and feedback value by the input signal.

#### Input terminal function

Positive logic	Negative logic	Function	Action (Positive logic)
54	55	PID plus/minus switching	Switch the PID plus / minus characteristics of the set value and the feedback value.

## 4. 3. 3 Agreement between set value and feedback value

It is possible to output agreement signal between the set value and the feedback value. Signal is output when difference between set by [F389] and the feedback value by [F360] are within  $\pm$  [F374].

Title	Parameter name	Description
F374	PID1 set value agreement detection band	Set the PID set value agreement detection band. 0.0 to [FH] (Hz)

### Output terminal function

Positive logic	Negative logic	Function	Action (Positive logic)
144	145	PID1,2 frequency command agreement	Difference between [F389] and [F369] are within $\pm$ [F167].

## 4. 3. 4 Switch to frequency command operation

You can switch from PID control to frequency command operation by input terminal signal. Assign "36: PID control OFF" to an unused input terminal. The inverter operates with the frequency set by [FM0d: Frequency command select 1] or [F207: Frequency command select 2].

### ■ Process type

The acceleration time and the deceleration time are set short for quick response of the PID control. You can use the second acceleration time and deceleration time if necessary.

### Input terminal function

Positive logic	Negative logic	Function	Action (Positive logic)
36	37	PID control OFF	Switch to frequency command operation after PID control is OFF

## 4. 3. 5 Deviation limit of PID control

When the setting value of [ACC] or [dEC] is made larger to have gradual acceleration/deceleration, the output frequency may be limited by the acceleration/deceleration operation and the frequency may become excessive at a rapid change of PID control output. In this case, set the deviation limit to avoid the influence of acceleration/deceleration operation.

\* Set the deviation limit up to the following values.

$$[F364] \leq \frac{[FH] \times [F363]}{[ACC]} \quad [F365] \leq \frac{[FH] \times [F363]}{[dEC]}$$



# 5 | PID control adjustment

## 5.1 Summary of adjustment

- In case with the estimate of PID gain

Set the estimated value of PID gain and check the operation of the system.  
Adjust the gain if necessary.

- In case without the estimate of PID gain

1) First, operate the inverter by default setting gain and check the operation of the system.

2) Adjust the fundamental gain.

(1) Adjust the proportional (P) gain when the response is delayed.

(2) Adjust the integral (I) gain when the unstable condition continues.

(3) Adjust the differential (D) gain when the system always changes or continues unstable condition even after PI gain adjustment.

3) Apply further adjustment for stability if necessary.

\* Adjust the primary delay filter to stabilize for speed type PID control.

## 5.2 Fundamental adjustment (common)

The fundamental gain of PID control adjusted according to the system.

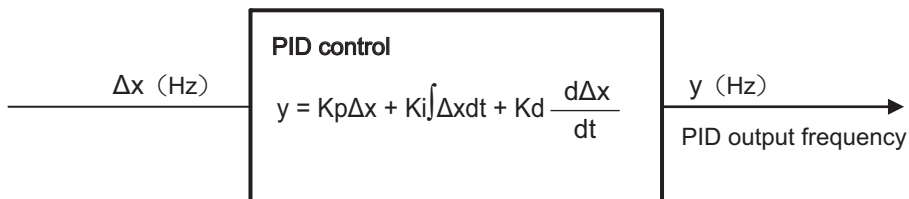

Symbol	Title	Parameter name	Setting value
$K_p$	F362	PID1 proportional gain	F362=1.0: $K_p = 1.0$
$K_i$	F363	PID1 integral gain	F363=1.0: $K_i = 1.0$ (s <sup>-1</sup> )
$K_d$	F366	PID1 differential gain	F366=1.0: $K_d = 1.0$ (s)

### 5. 2. 1 Proportional (P) gain

[F362] is the proportional (P) gain of PID1 control.

The proportional (P) gain, a factor gained by multiplying the deviation (difference between the set value and the feedback value), is used to perform control so as to make a correction in proportion to the deviation. Although larger gain is effective for quicker response, excessively high gain may cause an unstable operation including vibration.

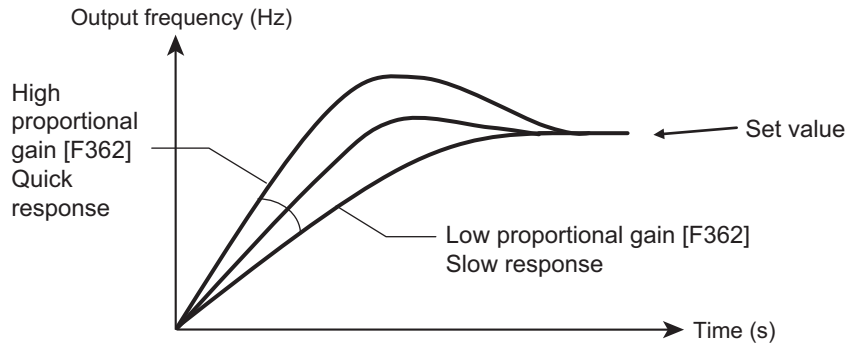

5

### 5. 2. 2 Integral (I) gain

[F363] is the integral (I) gain of PID1 control.

The integral gain reduces the deviation remaining after proportional control (residual deviation offset) to zero. Although larger gain reduces the residual deviation, excessively high gain may cause an unstable operation including vibration.

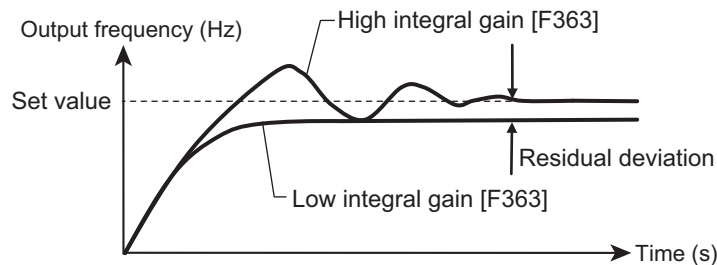

### 5. 2. 3 Differential (D) gain

[F366] is the differential (D) gain of PID1 control.

The differential gain increases the response speed in case of radical change in deviation. However, excessively high gain may cause instability including, considerable fluctuations of output frequency. Set to 0.00 (default setting) normally.

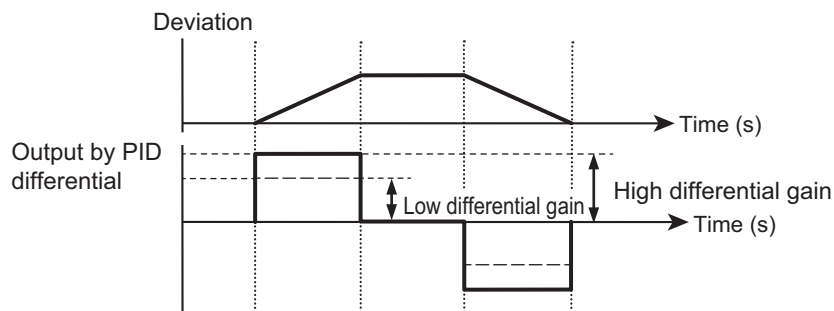

## 5.3 Applied adjustment (Common)

Make the following adjustments for increasing stability if necessary.

### 5.3.1 PID integral / differential reset

You can reset the PID integral value and differential value by input terminal signal.

#### Input terminal function

Positive logic	Negative logic	Function	Action (Positive logic)
52	53	PID differential/ integral reset	Reset the PID integral value and differential value.

### 5.3.2 PID control wait time

You can set the wait time to prevent PID control from starting before the system becomes stable.

Title	Parameter name	Description
F369	PID control start wait time	Inverter operates with frequency set by [FMOD] or [F207] within [F359] setting time. After [F359] setting time has elapsed, switch the PID control. (You can set operation during PID control start wait time by [A308].)

## 5.4 Applied adjustment (for speed PID control)

Adjust the following for stability of speed PID control if necessary.

### 5.4.1 Delay filter

Delay filter set by [F361] moderates radical change in deviation (primary delay control) to stabilize the system. Processing speed increases with the smaller setting value and decreases with the larger setting value. It is not necessary to change under normal conditions.

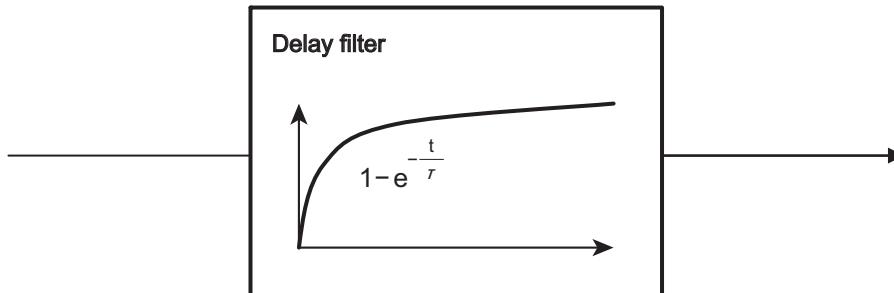

Symbol	Title	Function	Setting value
$\tau$	F361	PID1 filter	F361=1.0: $\tau=1.0$ (s)

### 5. 4. 2 Set value increase time, decrease time

[F372] and [F373] determine the response of feedback value. Set [F372] and [F373] to short for quick response.

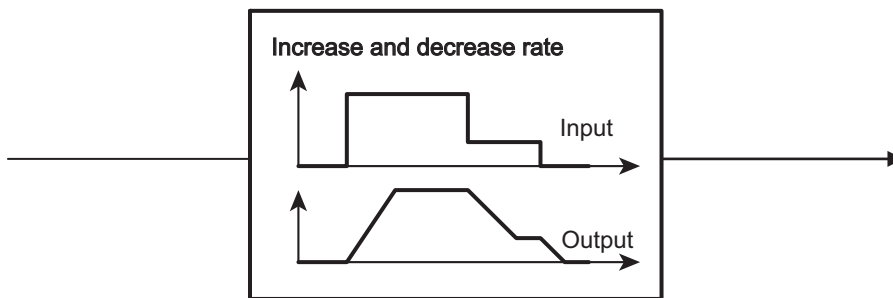

Symbol	Title	Setting value
F372	PID1 set value increase time	Time to reach from 0Hz to [FH] for converted frequency of the set value
F373	PID1 set value decrease time	Time to reach from [FH] to 0Hz for converted frequency of the set value



# 6 | Analog input characteristics

Set the analog input characteristics in case inputting the feedback value and the set value by the analog input terminals.  
 \*The following examples are setting from 0 to 60Hz

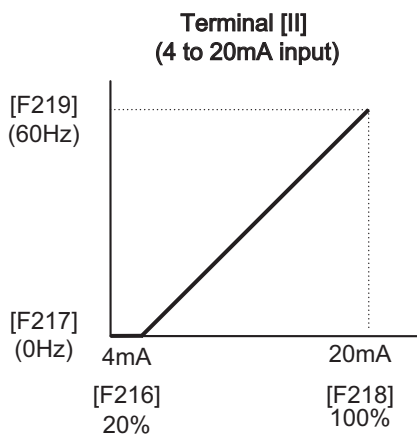
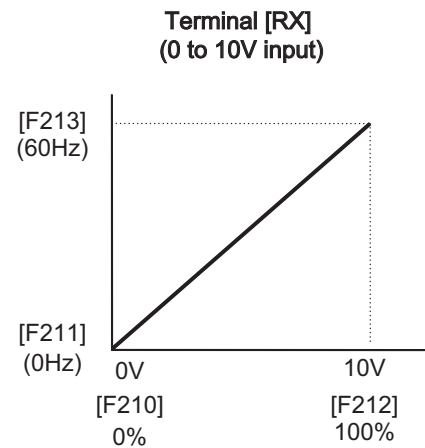
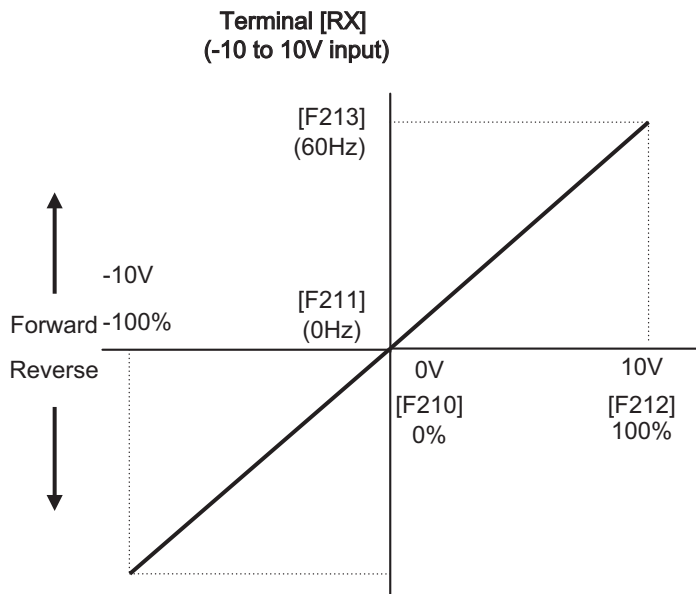
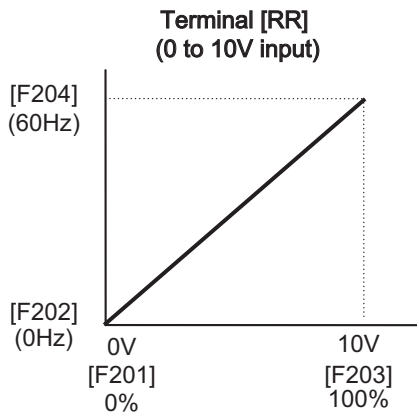

1
2
3
4
5
<b>6</b>
7
8
9
10



# 7 | PID2 control

The PID2 control has two types of PID control blocks internally, and they can be switched by the setting of [A300: PID1,2 switching target].

For example, you can perform the PID control for pressure in the normal situation, and the PID control for temperature under certain conditions.

In this case, the set values and feedback values for the pressure PID control and temperature PID control need to be input.

## ■ Diagram

Diagram of PID2 control is same as 2.1 to 2.4. Refer to chapter 8 for parameter.

## ■ Parameter setting

### 1) Select PID control type.

PID control types of PID2 are same as PID1 control, but polarity is selectable by [A310].

Example: When you select process type for PID1, PID2 is also process type PID control.

Title	Parameter name	Adjustment range
F359	PID control 1	0: Disabled 1: Process PID control 2: Speed PID control 3: Easy positioning PID control 4: Dancer control 5 - 10: - 11: Minus Process PID control 12: Minus Speed PID control 13: Minus Easy positioning PID control 14: Minus Dancer control
A310	PID control 2	0: Same polarity as PID1 1: Reverse polarity as PID1

Note 1) Not switch to PID2 control when [F359]= "3: Easy positioning PID control".

**2) Set parameters to switch PID1 and PID2 control.**

Title	Parameter name	Adjustment range
A300	PID1,2 switching target	0: Disabled 1: PID1 feedback 2: PID2 feedback 3: Terminal input 4: Time
A301	PID1,2 switching level	0 - 200 (%)
A302	PID1,2 switching hysteresis	0 - 200 (%)
A303	PID1 to PID2 switching time	0: Disabled 1 - 2400 (s)
A304	PID2 to PID1 switching time	0: Disabled 1 - 2400 (s)

- [A300] = "0": Only PID1 control
- [A300] = "1": When the PID1 control feedback value reaches  $([A301] + [A302])\%$  or more of the set value, a switch to the PID2 control. The PID1 control is enabled when the feedback value of it is  $([A301] - [A302])\%$  or less of the set value.
- [A300] = "2": The PID2 control is enabled when the feedback value of it is  $([A301] + [A302])\%$  or more of the set value. When the PID2 control feedback value reaches  $([A301] - [A302])\%$  or less of the set value, a switch to the PID1 control.
- [A300] = "3": When the input terminal with [116: PID 1, 2 switching] assigned is ON, the PID2 control is enabled. When it is OFF, the PID1 control is enabled.
- [A300] = "4": When the time of [A303] elapse from the start of the PID1 control, a switch to the PID2 control. When [A303] = "0: Disabled", this function is disabled.  
When the time of [A304] elapse from the start of the PID2 control, a switch to the PID1 control. When [A304] = "0: Disabled", this function is disabled.  
Note that the times of [A303] and [A304] do not include the PID control start wait time.

**3) Set PID1 control with reference to 2.1 to 2.4.**

**4) Set PID2 control with reference to chapter 8.**

**5) Set the following parameters if necessary.?**

Item	Title	Function
Set the operation at start-up for the case [F369: PID control start wait time] is set	A308	Operation during PID control start wait time 0: PID control disabled 1: PID1 enabled 2: PID2 enabled

- During the PID control start wait time, no switch occurs between the PID1 and PID2 controls even when [A300] is set to "1" or "2".
- There is no difference in output in switching to PID1/PID2 control. For example, when a switch from the PID1 to PID2 control is made, the output at the start of PID2 control matches the output at the end of PID1 control.

# 8

## Parameter list of PID2 control

Parameter name of PID2 control is same as PID1 control.

However, the choice of [A311], "12" is A327, and other choices are same as [F389].

Refer to 2.1 to 2.4 and chapter 3 for detail.

x: valid -: invalid

Parameter name	1. Process type	2. Speed type	3. Easy positioning	4. Dancer control	Parameter		Referen ce
					PID1 (1,2,3,4)	PID2 (1,2,4)	
PID set value select	x	x	-	x	F389	A311	Chap 3,8
PID feedback input select	x	x	-	x	F360	A312	Chap 3
PID filter	-	x	-	-	F361	A313	
PID proportional gain	x	x	x	x	F362	A314	
PID integral gain	x	x	x	x	F363	A315	
PID deviation upper-limit	x	x	x	x	F364	A316	
PID deviation lower-limit	x	x	x	x	F365	A317	
PID differential gain	x	x	x	x	F366	A318	
PID set value upper-limit	x	x	-	x	F367	A319	
PID set value lower-limit	x	x	-	x	F368	A320	
PID control start wait time	x	x	x	x	F369		
PID output upper-limit	x	x	x	x	F370	A322	
PID output lower-limit	x	x	x	x	F371	A323	
PID set value increase time	-	x	-	-	F372	A324	
PID set value decrease time	-	x	-	-	F373	A325	
PID set value agreement detection band	x	x	-	x	F374	A326	
PID set value (Operation panel)	x	x	-	x	FPId	A327	
PID output dead band	-	-	-	x	F388	A328	
Simple positioning completion range	-	-	x	-	F381	-	

- Input and output terminal function and monitor of PID2 control are same as PID1 control. Refer to chapter 3 for PID1 control.
- Easy positioning is invalid for PID2 control.



# 9 External PID control

Two types of PID control blocks are provided for controlling the external equipment such as valve and damper. This function can be enabled by setting the parameter or turning on/off the input terminal.

The following shows a block diagram of external PID control.

Use the parameters of external PID3 control and external PID4 control. The two types of PID control work independently. Only the process PID control is supported. The unit used for a set value, feedback value and PID control output is %. (The unit used for PID1/PID2 control is frequency.)

## ■ Diagram

### • External PID3 control

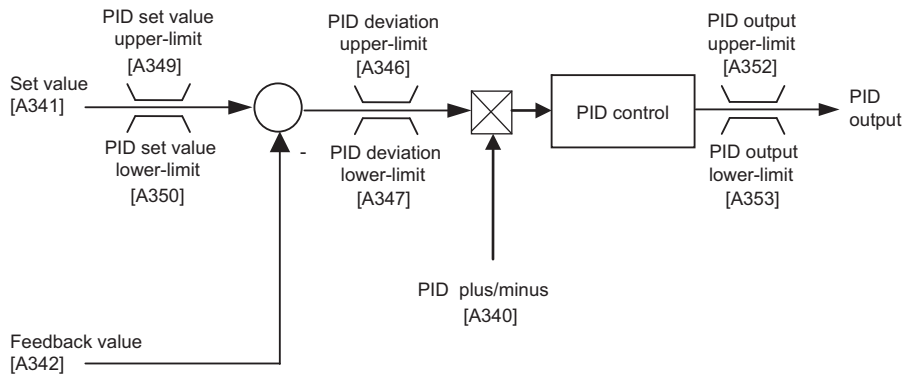

### • External PID4 control

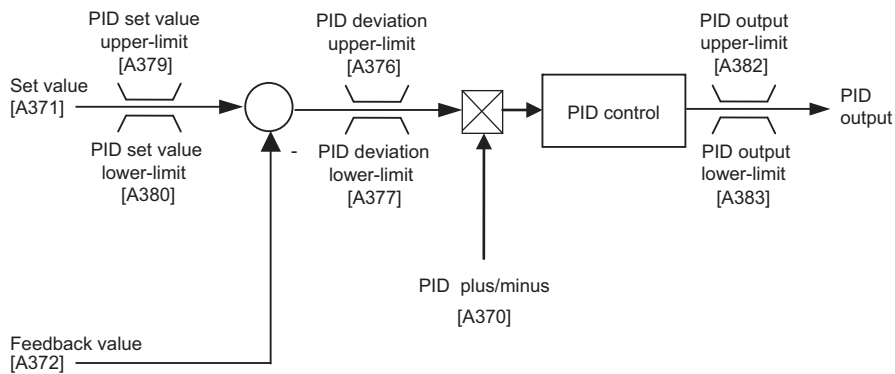

- The output at the time of enabling the external PID control is 0.
- When the external PID control is turned off, the output becomes 0.

1
2
3
4
5
6
7
8
9
10

■ **Parameter setting**

Parameter setting of external PID3 and PID4 are below.  
 PID3 and PID4 are independent each other.

**1) Select the input of set value and feedback value.**

Item	Title	Parameter name
Set value	A341	PID3 set value select
	A371	PID4 set value select
	A357	PID3 set value ([A341]= "12" )
	A387	PID4 set value ([A371]= "12" )
Feedback value	A342	PID3 feedback input select
	A372	PID4 feedback input select

**2) Set the following parameters to suit the system.**

Item	Title	Parameter name
Limit the input level of set value.	A349	PID3 set value upper-limit
	A379	PID4 set value upper-limit
	A350	PID3 set value lower-limit
	A380	PID4 set value lower-limit
Limit the level of PID output	A352	PID3 output upper-limit
	A382	PID4 output upper-limit
	A353	PID3 output lower-limit
	A383	PID4 output lower-limit
Switch the PID plus/minus characteristics.	A340	PID control 3 (with selection of plus/minus) PID control 4 (with selection of plus/minus) 0: Disabled 1: External Process PID control 2: External Process PID control (link with input terminal) 3 - 10: - 11: Minus external Process PID control 12: Minus external Process PID control (link with input terminal)
	A370	
	Input terminal function: "164/165: External PID3 plus/minus switching" "172/173: External PID4 plus/minus switching"	

- When [A340] is set to "2" or "12", the external PID3 control is enabled only when the input terminal to which [154: External PID3 enabled] is assigned is ON.
- When [A370] is set to "2" or "12", the external PID4 control is enabled only when the input terminal to which [156: External PID4 enabled] is assigned is ON.



### 3) Adjust the PID control gain.

Refer to chapter 5 for detail.

#### a) Fundamental adjustment

Item	Title	Parameter name
PID control gain	A344	PID3 proportional gain
	A374	PID4 proportional gain
	A345	PID3 integral gain
	A375	PID4 integral gain
	A348	PID3 differential gain
	A378	PID4 differential gain

#### b) Adjust the following parameter if necessary.

Item	Title	Parameter name
Steady the PID control. (Limit the PID deviation*1)	A346	PID3 deviation upper-limit
	A376	PID4 deviation upper-limit
	A347	PID3 output lower-limit
	A377	PID4 output lower-limit
Start the PID control after the system becomes stable.	A351	PID3 start wait time
	A381	PID4 start wait time

\*1 Deviation means difference between the set value and the feedback value.



# 10 | Parameter list of external PID control

## Parameters of external PID3 control

Title	Parameter name	Adjustment range	Default setting
A340	PID control 3	0: Disabled 1: External Process PID control 2: External Process PID control (link with input terminal) 3 - 10: - 11: Minus external Process PID control 12: Minus external Process PID control (link with input terminal)	0
A341	PID3 set value select	0: selected by FMOd/F207 1: Terminal RR 2: Terminal RX 3: Terminal II 4: Terminal AI4 (option) 5 - 11: - 12: A357	0
A342	PID3 feedback input select	0: - 1: Terminal RR 2: Terminal RX 3: Terminal II 4: Terminal AI4 (option)	0
A344	PID3 proportional gain	0.01 - 100.0	0.30
A345	PID3 integral gain	0.01 - 100.0	0.20
A346	PID3 deviation upper-limit	0.0 - 250.0 (%)	100.0
A347	PID3 deviation lower-limit	0.0 - 250.0 (%)	100.0
A348	PID3 differential gain	0.00 - 2.55	0.00
A349	PID3 set value upper-limit	0.0 - 250.0 (%)	100.0
A350	PID3 set value lower-limit	0.0 - A349 (%)	0.0
A351	PID3 start wait time	0 - 2400 (s)	0
A352	PID3 output upper-limit	0.0 - 250.0 (%)	100.0
A353	PID3 output lower-limit	0.0 - 250.0 (%)	0.0
A357	PID3 set value	A350 - A349 (%)	0.0

## Parameters of external PID4 control

Title	Parameter name	Adjustment range	Default setting
A370	PID control 4	0: Disabled 1: External Process PID control 2: External Process PID control (link with input terminal) 3-10: - 11: Minus external Process PID control 12: Minus external Process PID control (link with input terminal)	0

Title	Parameter name	Adjustment range	Default setting
A371	PID4 set value select	0: selected by FMOd/F207 1: Terminal RR 2: Terminal RX 3: Terminal II 4: Terminal AI4 (option) 5 - 11:- 12: A387	0
A372	PID4 feedback input select	0: - 1: Terminal RR 2: Terminal RX 3: Terminal II 4: Terminal AI4 (option)	0
A374	PID4 proportional gain	0.01 - 100.0	0.30
A375	PID4 integral gain	0.01 - 100.0	0.20
A376	PID4 deviation upper-limit	0.0 - 250.0 (%)	100.0
A377	PID4 deviation lower-limit	0.0 - 250.0 (%)	100.0
A378	PID4 differential gain	0.00 - 2.55	0.00
A379	PID4 set value upper-limit	0.0 - 250.0 (%)	100.0
A380	PID4 set value lower-limit	0.0 - A379 (%)	0.0
A381	PID4 start wait time	0 - 2400 (s)	0
A382	PID4 output upper-limit	0.0 - 250.0 (%)	100.0
A383	PID4 output lower-limit	0.0 - 250.0 (%)	0.0
A387	PID4 set value	A380 - A379 (%)	0.0

## Input /Output terminal function

Terminal	External PID3		External PID4		Function
	Positive logic	Negative logic	Positive logic	Negative logic	
Input terminal	154	155	156	157	External PID enabled
	162	163	170	171	External PID differential/integral reset
	164	165	172	173	External PID plus/minus switching
Output terminal	206	207	210	211	External PID deviation limit
	204	205	208	209	During External PID control

## FM/AM/pulse output and monitor output function

FM/AM/pulse output and monitor output					Function
External PID3		External PID4			
Set No.	Communication No.	Set No.	Communication No.		
130	FD96	133	FE96	External PID set value	
131	FD97	134	FE97	External PID feedback value	
132	FD98	135	FE98	External PID result value	



