

MULTI-THERM[®] 500 GOLD

Fiberglass Jacketed, Steel Conduit System
with Multi-Layered Corrosion Protection



The First District Energy
Preinsulated Piping
System Incorporating
the Corrosion Protection
Technology of the Oil
and Gas Industry

PERMA-PIPE[®]



CORROSION



PREMATURE FAILURE



COSTLY REPAIRS and REPLACEMENTS

MULTI-LAYER CORROSION PROTECTION



MULTI-THERM® 500 GOLD CORROSION PROTECTION for District Heating applying the same technology as used in the Oil and Gas Industry.

Now for the first time in District Heating and Cooling, PERMA-PIPE introduces the same corrosion protection technology used in the Oil and Gas industry. An additional corrosion coating layer is applied to the outer casing prior to the application of the polyurethane foam and fiberglass jacket. This coating will protect the steel in the event the outer jacket is ever breached during operation.

Shot Blasted Steel Conduit

For the best corrosion protection the steel substrate must be blasted to a near white surface. The resulting profile and anchor pattern allows the coating to properly adhere for maximum protection and long life.

Outer Conduit Coating

PERMA-PIPE offers three different coating options: Epoxy, Urethane Elastomer and Zinc. Epoxy is one of the most widely used coatings in a wide variety of industrial applications. Urethane Elastomers have been used for many years for direct burial in all types of soils. Zinc is an excellent coating for high temperatures

and when boiling conditions may be present.

Polyurethane Spray Foam Insulation

MULTI-THERM® 500 GOLD is designed to maintain the conduit temperature below 250°F. Therefore, the conduit can be safely insulated with polyurethane foam. PERMA-PIPE uses only spray applied foam which has many advantages over injected foams. Spray foam is 100% void free and has better insulation value, compressive strength, uniform cell structure and concentricity than injected foams.

Fiberglass Jacket

PERMA-PIPE's multidirectional filament winding process produces a high strength, high temperature fiberglass jacket over the outer foam insulation to ensure maximum protection from the environment. This jacket provides complete protection to the insulation and conduit eliminating the need for cathodic protection which saves additional material, installation and maintenance costs.

SYSTEM COMPONENTS MULTI-THERM® 500 GOLD

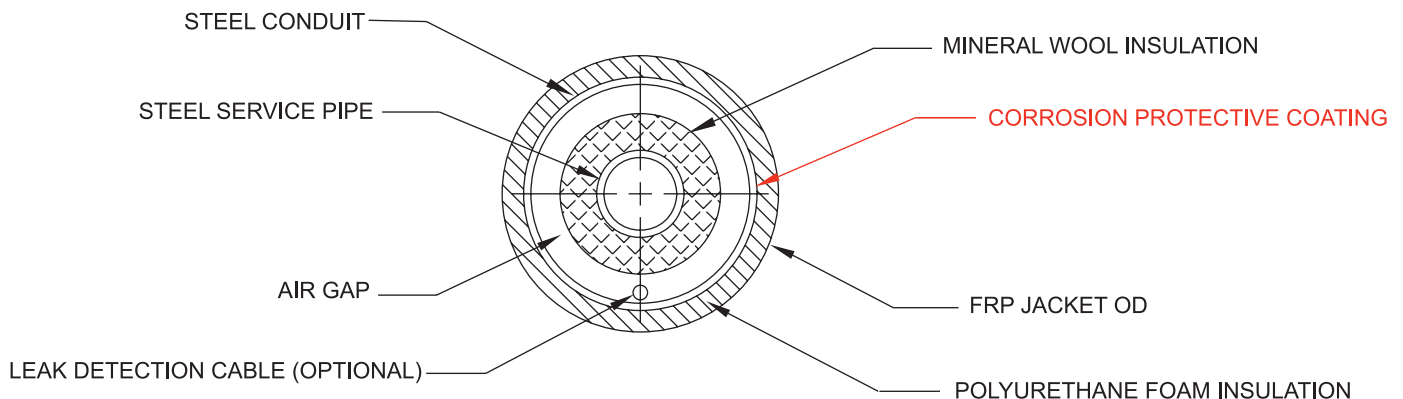

Fiberglass Jacketed Steel Conduit

MULTI-THERM® 500 GOLD is the only preinsulated piping system that combines both the strength of steel and the corrosion resistance of fiberglass. Using the heat resistance of mineral wool insulation along with the thermal efficiency of polyurethane foam insulation, it is also the most energy efficient system available. This innovative piping system unites these materials in a unique combination to satisfy the most demanding criteria for underground heat distribution systems.

The steel service pipe is insulated with mineral wool insulation and contained within a drainable, dryable, pressure testable steel conduit. This combination alone would be an excellent piping system, but we also corrosion coat the conduit, insulate it with polyurethane foam and jacket it with fiberglass. This union is formed to complete the highest quality, waterproof, corrosion resistant, high strength, thermally efficient system available.



**PAL-AT
Leak Detection/Location System**

Recommended insulation thicknesses and heat losses for mineral wool and cellular glass insulation.

Note: All conduits are insulated with 1" thick polyurethane foam.

Nominal Pipe Size (In)	Mineral Wool Thickness (In)	Conduit O.D. (In)	Heat Loss (BTU/ FT-HR)
2	1	6 ⁵ / ₈	41
3	1½	10¼	50
4	1½	12¾	56
6	1½	12¾	71
8	2	16	77
10	2	18	88
12	2	20	99
14	2	22	109
16	2	24	120
18	2½	26	119
20	2½	28	129
24	2½	32	148

Based on 3 foot burial depth, 353°F operating temperature, 40°F ground temperature and soil conductivity of 15 BTU-IN/HR-FT².°F.

Options

- Leak Detection/Location
- Electric or Steam Heat Traced
- Cathodic Protection - not required

PAL-AT Leak Detection and Location System

It is recommended that drainable, dryable systems be installed dry, to achieve a longer period of satisfactory performance and improved system life. MULTI-THERM® 500 GOLD can be provided with the advanced electronic monitoring system, PAL-AT, that provides full time surveillance for system integrity. The PAL-AT continuously monitors for the presence of moisture in the conduit and will signal the location of any moisture. This system ensures that the conduit is installed dry and continues to stay dry.

MULTI-THERM® 500 GOLD SPECIFICATION GUIDE

GENERAL

All underground distribution lines, as shown on the contract drawings shall be MULTI-THERM® 500 GOLD, as manufactured by PERMA-PIPE. The system supplier shall have at least five years experience fabricating systems of the composition defined herein. All straight sections, fittings, anchors and other accessories shall be factory pre-fabricated to job dimensions. Each system layout shall be computer analyzed by the piping system manufacturer, to determine stresses and movements of the service pipe. The system design shall be in strict conformance with ANSI B31.1, latest edition, and stamped by a Registered Professional Engineer.

SERVICE PIPE

Internal piping shall be standard weight carbon steel, except for condensate piping which shall be Schedule 80. Pipe shall be butt welded for sizes 2.5 inches and larger and socket welded for 2 inches and below. Where possible, straight sections shall be supplied in 40 foot random lengths with 6 inches of piping exposed at each end for field joint fabrication.

SUBASSEMBLIES

End seals, gland seals and anchors shall be designed and factory prefabricated to prevent the ingress of moisture into the system. All subassemblies shall be designed to allow for complete draining and drying of the conduit system.

SERVICE PIPE INSULATION

Service pipe insulation shall be mineral wool. Split insulation shall be held in place by stainless steel bands installed not more than 18 inches apart. The insulation shall have passed the boiling test requirements specified in the Federal Agency Guidelines.

PIPE SUPPORTS

All pipes within the outer conduit shall be supported to allow for continuous drainage of the conduit in place. Supports shall be the type where insulation thermally isolates the service pipe from the outer conduit. The surface of the support insulation shall be protected by a steel sleeve not less than 12 inches long.

OUTER CONDUIT

The steel conduit casing shall be smooth wall, welded steel conduit of the thicknesses specified below:

Conduit Size	Conduit Thickness
6" - 26"	10 Gauge
28" - 36"	6 Gauge
38" - 42"	4 Gauge

Changes in casing size, as required at oversized casing to allow for service pipe expansion, shall be accomplished by eccentric and/or concentric fittings and shall provide for continuous drainage.

OUTER CONDUIT COATING

The exterior steel conduit surface shall be abrasive blast-cleaned to a minimum of a near white surface, SSPC-SP10-63T. Profile must be a minimum of 1.5 mil peak to valley range. Any areas of rust bloom or oil shall be wiped and reblasted.

After blasting, the steel conduit shall be coated with (choose one option),(Epoxy) (Urethane Elastomer) (Zinc).

The epoxy coating shall be a two part coating consisting of a base material and curing agent spray applied to a minimum thickness of 8-12 mil. The coated conduit shall be holiday tested at 1,000 volts to ensure a void free coating. Areas of the conduit not passing the holiday test shall be patch coated and retested

The urethane elastomer coating shall be a sprayable two component, aromatic, corrosion protection elastomeric coating applied to a minimum thickness of 20 mil. The coated conduit shall be holiday tested at 2,500 volts to ensure a void free coating. Areas of the conduit not passing the holiday test shall be patch coated and retested.

The zinc coating shall be a high solids inorganic coating that protects the steel galvanically, thus eliminating sub-film corrosion. The zinc coating shall be a two part sprayable coating consisting of a liquid base portion and a dry powdered metal. The two components when mixed together can be spray applied. The dry film thickness shall be in a range of 2 to 4 mil.

OUTER CONDUIT INSULATION AND JACKET

Conduit insulation shall be spray applied polyurethane foam having a minimum density of 2 lb/ft³ for the straight lengths and fittings. The insulation thickness shall be 1 inch maximum. The polyurethane foam shall have a maximum initial K value of 0.18, minimum density of 2 lb/ft³ and a minimum closed cell content of 90%.

The outer jacket shall be fiberglass reinforced polymer (FRP) and shall be applied directly onto the urethane foam insulation. No PVC or polyethylene jackets shall be allowed. All straights and fittings shall be factory jacketed.

PERMA-PIPE®

PERMA-PIPE, INC.

A Subsidiary of MFRI, Inc.
7720 North Lehigh Avenue
Niles, Illinois 60714-3491
Phone (847) 966-2235
Fax (847) 470-1204
www.permapipe.com

The information contained in this document is subject to change without notice. PERMA-PIPE believes the information contained herein to be reliable, but makes no representations as to its accuracy or completeness. PERMA-PIPE, Inc., a subsidiary of MFRI, Inc., sole and exclusive warranty is as stated in the Standard Terms and Conditions of Sale for these products. In no event will PERMA-PIPE be liable for any indirect, incidental, or consequential damages.