

# ISE-MAGTECH

## LG SERIES LIQUID LEVEL GAGES

### INSTRUCTION MANUAL

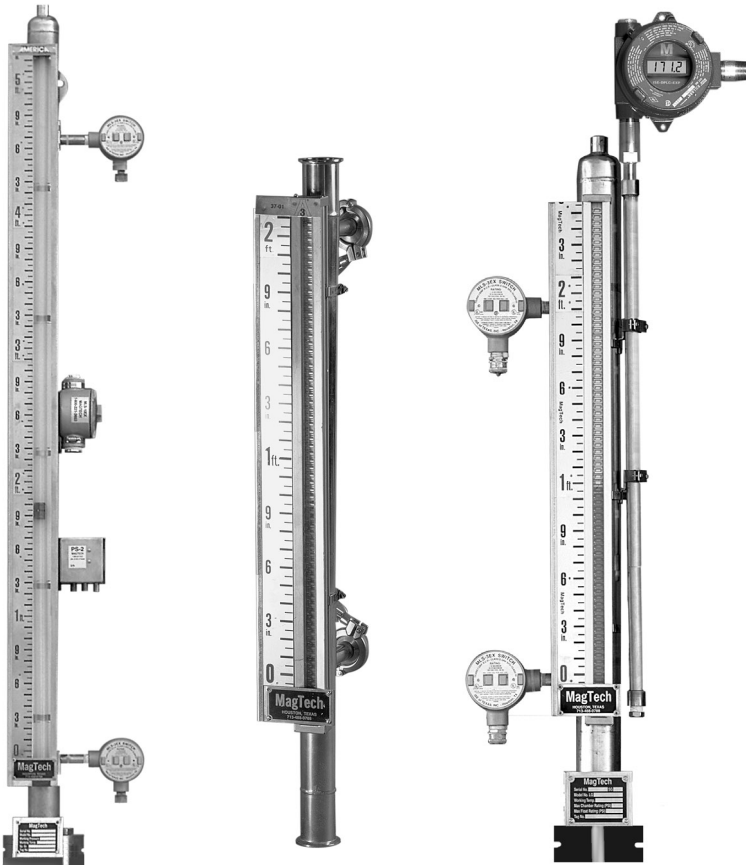

- Visual indication from 100 ft.
- No process liquid in contact with glass
- Metallic flags or shuttle indicator (hermetically sealed)
- Welding specifications to boiler/piping codes (ASME B31.1/B31.3)
- Non-invasive alarms and transmitters
- For high temperature, pressure and corrosive service
- Replace problem sight glasses

# TABLE OF CONTENTS

Page 1	Detailed Description
Page 1	Standard Indication
Page 1	Flipper/Roller Indication (Optional)
Page 1	Installation
Page 1	Pressure Testing
Page 1	Flanges & Connections
Page 2	Placing the Gage in Service
Page 2	Removing the Gage from Service
Page 2	Routine Maintenance
Page 3	LG Series Parts List
Page 3	Flipper/Roller Retrofit
Page 3	Troubleshooting Level Gages
Page 4	MLS-3, MLS-3EX Level Switches
Page 5	MLS-5EX, MLS-10EX Level Switches
Page 6	PS-2 Pneumatic Switch
Page 7	LT-1 2-Wire Transmitter
Page 8	LT-1 Transmitter - Diagram
Page 9	Gage Mount-LTM Transmitter
Page 9	Field Insulation of Gages w/ Transmitters
Page 10	Terms & Conditions / Warranty

## DETAILED DESCRIPTION

The LG Series Level Gage consists of a glass (or polycarbonate) indicator or Flipper/Roller and float chamber, which is mounted directly to the process vessel. Standard gages are normally flanged or coupled to the process vessel, but a variety of mounting styles are available to suit most any vessel or piping requirements. (See Table 1 of the brochure for more details.)

Gages are manufactured to meet the exact specifications of the process such as operating pressure, temperature, specific gravity, etc. Standard materials are stainless steel, however most any non-magnetic material may be used including PVC, Kynar, Hastelloy, Monel, Alloy 20, and many others. A magnetized float is contained inside the chamber, which is designed to meet the requirements of the process conditions. (For this reason, floats are not interchangeable unless process conditions are similar.) The float moves freely inside the gage chamber as level rises and falls. Under normal conditions, the float should be about 70% submerged in the process fluid, but it is important to note that the position of the float in the fluid will vary with different process conditions.

### STANDARD INDICATION

The scale assembly used for indicating level consists of the clear indicator tube with the red magnetic follower or “bird” and a graduated scale marked with feet and inches (special scales are available, i.e.: metric, gallons, 0-100%, etc.). The scale is mounted parallel and immediately next to the indicator tube. The tube is hermetically sealed to prevent moisture and dirt accumulation. A rubber “bumper” is sealed inside the bottom of the tube to cushion the impact of the “bird” against the glass. The bright red bird provides maximum visibility (even at night), however light kits for illuminating gages are available. A black reference line around the bird allows the operator to match the graduated scale with the actual level of the process fluid. Positive zero indication is provided by a nameplate at the lower end of the scale. If the bird is de-coupled from the float, the bird will fall down behind this nameplate and will not be visible. Thus, when the vessel is empty, the level gage will read zero and the bird is still visible. To prevent the float from losing magnetic coupling with the bird, a spring or stop plate is mounted into the top and bottom of the gage chamber. This cushions the impact of the float against the chamber when the process vessel is completely full or empty.

### FLIPPER/ROLLER INDICATION (OPTIONAL)

MagTech offers a flipper/roller style indicator as an option to the standard tube/follower indicator. “Flippers” are industrial grade indicators, which consist of a series of metal flags, silver on one side and red on the other. As the magnetic float moves up and down with the level, each flag will rotate 180° to show the other color. MagTech flippers are housed in a rugged, hermetically sealed aluminum housing with a recessed glass window. Each flag rotates on a ceramic and stainless steel bearing surface, which eliminates “sticking” or hanging up. Flipper assemblies are built to the length of the level gage in one continuous piece up to 20 feet with no joints or blind spots.

### FLIPPER/ROLLER INDICATION (OPTIONAL) (Cont.)

Flipper assemblies are offered as an option to the standard MagTech indicator where surging or turbulent levels may cause “de-coupling” problems. They have higher visibility than the standard indicator. They come with or without the scale in feet and inches.

### INSTALLATION

LG Series gages are securely packed in specially designed crates to provide maximum protection of the glass tube and float chamber during shipment. It is important to unpack and inspect each gage upon receipt to insure the glass tube and chamber are free from damage. If you should find bent or broken parts, contact MagTech immediately. All MagTech gages are fully insured against damage or loss (unless otherwise specified by customer), however claims must be filed within 15 days from date of receipt of shipment.

The float chamber should always be leveled vertically. If it is not leveled vertically, the float may become magnetically uncoupled from the bird. Should this happen during installation, simply use a permanent magnet or magnet tool (available from MagTech) to pull the bird back up to the float’s magnetic field. See the **TROUBLESHOOTING** section of this manual for more details on re-coupling float and birds.

Valves should be installed between the process vessel and level gage to allow draining, cleaning, etc. Standard block valves may be used and can be ordered with the gage from MagTech or supplied by the customer. All gages are shipped complete with 0.125 inch composition gaskets. **NOTE: IF COMPOSITION GASKETS ARE NOT COMPATIBLE WITH YOUR PROCESS CONDITIONS, APPROPRIATE GASKETS SHOULD BE USED IN PLACE OF THOSE SHIPPED WITH THE GAGE.**

### PRESSURE TESTING

All MagTech gages are hydrostatically tested to 1.5 times the specified flange/pressure rating prior to shipment to insure pressure tolerance. However, the gage should be blocked in or the float removed if the process vessel is to be pressure tested in the field by the customer as most vessels are tested at much higher pressures than the maximum operating process pressure. While the float chamber is capable of withstanding these higher pressures, the float is not and may collapse under vessel tests. Should floats be damaged during testing, replacements are supplied at the customer’s expense.

### FLANGES & CONNECTIONS

Process connections and vent/drain flanges are designed to meet each customer’s specifications. The graduated scale assembly is based on the length of the float chamber from center to center of the process connections. All flange bolt holes straddle the center lines unless otherwise specified. On STYLE A Level Gages “stop plates” are supplied to insure the float is contained inside the chamber. For more information on dimensions, flanges, etc., see Table 1-3 in the brochure.

## **IMPORTANT!!!**

**IF YOU DON'T READ ANY OTHER PART OF THIS MANUAL, PLEASE READ THIS PAGE. IT WILL SAVE YOU TIME, MONEY AND MUCH FRUSTRATION.**

### **PLACING THE GAGE IN SERVICE**

To insure proper operation of the level gage, the following steps should be taken:

1. Make sure that operating conditions (temperature, pressure, specific gravity, etc.) are within maximum rating of the gage. Each gage has a permanent nameplate at the bottom of the scale indicating process specifications, serial number, tag number, etc.
2. Install float. The float is marked "TOP" to insure proper orientation.
  - 2a. On STYLE E Level Gages (Top Mount) remove float stop.
  - 2b. STYLE A Level Gages are supplied with float stops which should be installed between top and bottom process connections.
3. The float chamber should be closed with no openings to the atmosphere. Check to see that all drain and vent plugs are securely in place and any vent and drain valves are closed.

**IMPORTANT NOTE: THIS STEP IS VERY IMPORTANT IN HIGH PRESSURE APPLICATIONS. IF THE BOTTOM VALVE IS OPENED FIRST AND THE VESSEL IS UNDER PRESSURE, THE FLOAT INSIDE THE CHAMBER WILL SHOOT UP LIKE A "CANNONBALL" AND COULD LODGE IN THE TOP OF THE CHAMBER CAUSING SEVERE DAMAGE TO THE FLOAT AND CHAMBER.**

4. When the gage is mounted and ready to be put into service, the TOP process connection valve should be opened first and should be opened slowly to allow any pressure to equalize. This allows process fluid or vapor to enter the gage slowly and reach operating pressure and temperature at a reasonable rate.
5. When the gage has reached process pressure, then open the bottom process connection and installation should be complete.

**CAUTION: NEVER USE THE VENT OR DRAIN ON THE GAGE AS A PRESSURE RELIEF FOR THE PROCESS. DOING SO MAY PERMANENTLY DAMAGE GAGE AS WELL AS CAUSING HAZARD TO PERSONNEL.**

### **REMOVING THE GAGE FROM SERVICE**

To remove the gage from service, the following steps should be followed carefully:

1. Close the BOTTOM process connection valve to prevent further filling of the gage. Then close the TOP process connection valve to completely isolate the gage from the process pressure.
2. Attach proper vapor collection equipment to the gage vent connection if required. Open the top vent to relieve pressure in the gage and allow air to flow when the bottom drain is opened.
3. Attach the proper liquid collection equipment to the bottom drain and remove liquid. After all process fluid is out of the gage, the gage is then ready to be removed from service.

### **ROUTINE MAINTENANCE**

Standard MagTech gages have a ½ inch vent and drain plug in the top and bottom of the float chamber to allow cleaning and removal of the process fluid as required. Some gages are connected by the customer to a solvent or steam line, which allows them to be decontaminated or "blown down" periodically without taking the gage out of service or removing the drain flange and float. MagTech gages should be cleaned and inspected at least on an annual basis, or more frequently depending on the severity of the process. To perform maintenance and clean gage, follow these procedures:

1. Block in the float and chamber with the process connection valves or wait until the vessel is empty or out of service. Follow the steps on previous page for "Removing the Gage from Service".
2. When all the fluid has been drained from the gage chamber, remove the drain flange and let the float slide out of the chamber. Be sure to examine the float for excessive wear and clean as required.
3. Clean the inside wall of the chamber with a "bottle brush" or similar scrubbing tool. Some processes may dictate the use of suitable solvent for cleaning.
4. If the gage is located where the bottom drain is near the floor or other equipment where it is difficult to reach, it is possible to order gages with a top flange in place of the standard vent plug, or inverted where drain flange would become the top and the weld cap would be on the bottom. This allows the gage to be cleaned and serviced through the top end.
5. After cleaning the chamber, replace the float and drain flange. A new flange gasket may be required. (Note: Make sure to use gaskets compatible with the process fluid if replaced.)
6. Check the stainless steel pipe clamps to insure they are tight and adjust the scale holder up or down on the float chamber to make sure the positive zero is correctly positioned.

## ROUTINE MAINTENANCE (CONT.)

7. Use a permanent magnet or a magnet tool from MagTech to attract the red "bird" until it is again coupled to the float inside the chamber on standard indication.

## LG SERIES PARTS LIST

When ordering replacement parts for MagTech Gages, the following information is required:

1. Serial Number of gage or accessory item
  2. Description of item
  3. Original purchase order if possible
- A. TYPICAL FLOAT CHAMBER PARTS
1. Vent plug and spring
  2. Drain flange and spring
  3. Drain plug
  4. Magnetized float
  5. Top float spring
  6. (Style A Only) Float stop plates with spring
- B. INDICATOR SCALE ASSEMBLY
1. Scale/Channel Assembly
  2. Indicator Tube (glass or polycarbonate)
  3. Pipe Clamps
  4. Name Plate
  5. Indicator Tube mounting blocks (top and bottom)
- C. FLIPPER/ROLLER OPTION

## FLIPPER/ROLLER RETROFIT

### INSTALLATION & START-UP

When flipper indicators are purchased with a MagTech gage no installation is necessary. However, if the indicator is removed or a retrofit kit is purchased for a gage already in service, the following should be noted:

1. The mounting clamps connecting the flipper assembly to gage chamber, are adjustable to most manufacturers' standard (i.e.: 2" to 3" pipe).
2. If the gage is in service and there is liquid in the tank, only the individual flippers adjacent to the float will rotate to red when the indicator assembly is clamped on.
3. To reset indicator to show true level, the operator can
  - a. Run a magnet along window of indicator from 0 to where red is showing as noted in item 2

OR

  - b. Drain gage to empty to zero the indicator, then fill again and as float rises with the level indicator will then be set and read properly  
(red = liquid, silver = vapor space).

## TROUBLESHOOTING

### MAGTECH LEVEL GAGES

MagTech gages are a relatively simple to install and use. The following troubleshooting tips may be of help during installation and startup but reading the entire manual helps even more.

1. **"Float magnetically de-couples from red indicator "bird".**  
(Note: if bird is de-coupled, it will fall behind nameplate and will not be visible.)  
If this is a recurring problem, it could be caused by several things, most of them resulting from improper installation of the gage.
  - a. Check to make sure that scale and channel assembly is tight against the gage chamber the entire length of the scale so that magnetic coupling is maintained from top to bottom of the indicator tube. Sometimes, especially with longer gages over 5-6 feet, the glass will bow out slightly and the float will lose coupling with the bird at some point. Stainless steel tie-wires are supplied with gages over 5 feet long to keep the glass from bowing out. Make sure these tie-wires are in place, tightened and secure.
  - b. Check to make sure the float inside the chamber is right side up. If the float has been placed in the chamber upside down, it has only half-normal magnetic strength and will de-couple from the indicator bird. All floats are clearly marked "TOP".
  - c. If float-stop springs or plates mounted in the top and bottom of the gage chamber have been removed, the float will continue to rise past the top of the indicator tube and will lose coupling with the bird at that point.
  - d. Sudden violent surges of process fluid could cause de-coupling. If this is a common problem, de-coupling may be minimized by partially closing the process connection valves (or retrofit gage with flipper/roller option).
  - e. If the center-to-center dimension has been miscalculated and the gage is slightly too long, do not force it into place as this may cause the chamber to bow slightly and the float will not be able to pass freely through the entire length of chamber. This will also cause de-coupling.

If none of the above tips applies to your de-coupling problem, contact MagTech for more information or for replacement floats and/or indicators. Also note that magnets exposed to extreme temperatures (over 1100°) will lose their magnetic properties. Other problems that could damage float causing de-coupling problems include over pressurization, solids or large particulate lodged in the chambers or even dropping the float.

2. **"MagTech gage's level differs from true level in the tank."**

This is a fairly common problem during start-up and is easily corrected. Under normal conditions, most floats are about 70% submerged in the process fluids (magnets are in upper portion of the float).

It is important to note that the position of the float in the fluid will vary with different process conditions. To get a true reading, simply loosen the pipe clamps that mount the indicator scale and tube and adjust the scale up or down the chamber as required to get an exact reading (within ½ inch).

## TROUBLESHOOTING (Cont.)

### 3. “Indicator tube is cracked or broken.”

If the glass indicator tube is cracked or broken replacement can be shipped usually within 24 hours after ordered. One of the advantages of the MagTech gage is the glass is easily replaced without taking the gage out of service or shutting down the process. To replace the glass, loosen the two screws in the PVC or Teflon block located in the top or bottom of the scale assembly, remove the block and slide out the broken glass. If the gage is over 6 feet tall, it may be easier to remove the entire scale and channel by loosening the pipe clamps and taking it off the gage. This will protect the new glass when replacing it and remounting it to the gage chamber.

### 4. “Level switches don’t trip properly.”

All level switches may be wired to trip on rising or falling level. After the switch is wired for the desired alarm action (see instructions in this manual), it is necessary to set the switch. This is easily accomplished by passing the float either manually or by filling the gage chamber till it passes the highest switch. This will trip the switch to the desired setting so it will alarm properly with rise or fall of level.

## GAGE MOUNT LEVEL SWITCHES

### MLS-3, MLS-3EX LEVEL SWITCHES

#### SPECIFICATIONS

Deadband:	.50 Inches
Max. Temperature:	650°F - HT Version 350°F - STD Version
Min. Temperature:	-40°F
Contacts:	Form C SPDT
Maximum Ratings:	
Switching Voltage:	150 Volts AC/DC
Current:	1.0 Amps AC/DC
Power:	25 Watts DC/VA

#### SWITCH OPERATION/MOUNTING

To mount the MLS Series Level Switch simply clamp it directly to the side of the level gage chamber using the adjustable pipe clamps provided. Alarm set points may be changed by simply loosening the clamps and sliding the switch to the desired alarm level. To set up desired starting state follow the steps below:

#### WIRING DETAILS

##### RISING LEVEL ALARM

MLS-3	Yellow	Green	Red	Green	
MLS-3EX		A(NC)	C	B(NO)	C

##### FALLING LEVEL ALARM

MLS-3	Red	Green	Yellow	Green	
MLS-3EX		B(NC)	C	A(NO)	C

##### SCHEMATIC

##### MLS-3 / MLS-3EX

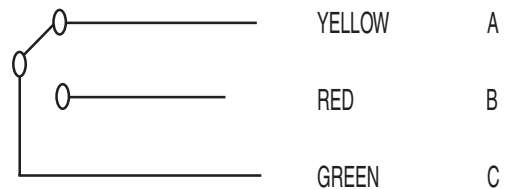

# GAGE MOUNT LEVEL SWITCHES (CONT.)

## MLS-5EX LEVEL SWITCH

### SPECIFICATIONS

Deadband: .50 Inches  
 Max. Temperature: 650°F - HT Version  
 350°F - STD Version  
 Min. Temperature: -40°F  
 Contacts: Form C DPDT

Maximum Ratings:  
 Switching Voltage: 240V/30V AC/DC  
 Current : 5 Amps  
 Power: 1KVA/150W

Contact Ratings:  
 5A @ 240VAC resistive  
 5A @ 120VAC resistive  
 5A @ 30VDC resistive  
 1/8HP @ 250VAC

1.5A @ 240VAC inductive (cosec=0.4)  
 1.5A @ 120VAC inductive (cosec=0.4)  
 1.5A @ 24VDC inductive (L/R=7msec)

## MLS-10EX LEVEL SWITCH

### SPECIFICATIONS

Deadband: .50 Inches  
 Max. Temperature: 650°F - HT Version  
 350°F - STD Version  
 Min. Temperature: -40 °F  
 Contacts: Form C DPDT

Maximum Ratings:  
 Switching Voltage: 240V/30V AC/DC  
 Current : 10 AMPs  
 Power: 1KVA/150W

Contact Ratings:  
 10A @ 240VAC resistive  
 10A @ 120VAC resistive  
 10A @ 30VDC resistive  
 1/8HP @ 250VAC

8A @ 240VAC inductive (cosec=0.4)  
 8A @ 120VAC inductive (cosec=0.4)  
 8A @ 24VDC inductive (L/R=7msec)

### MLS-5EX & MLS-10EX

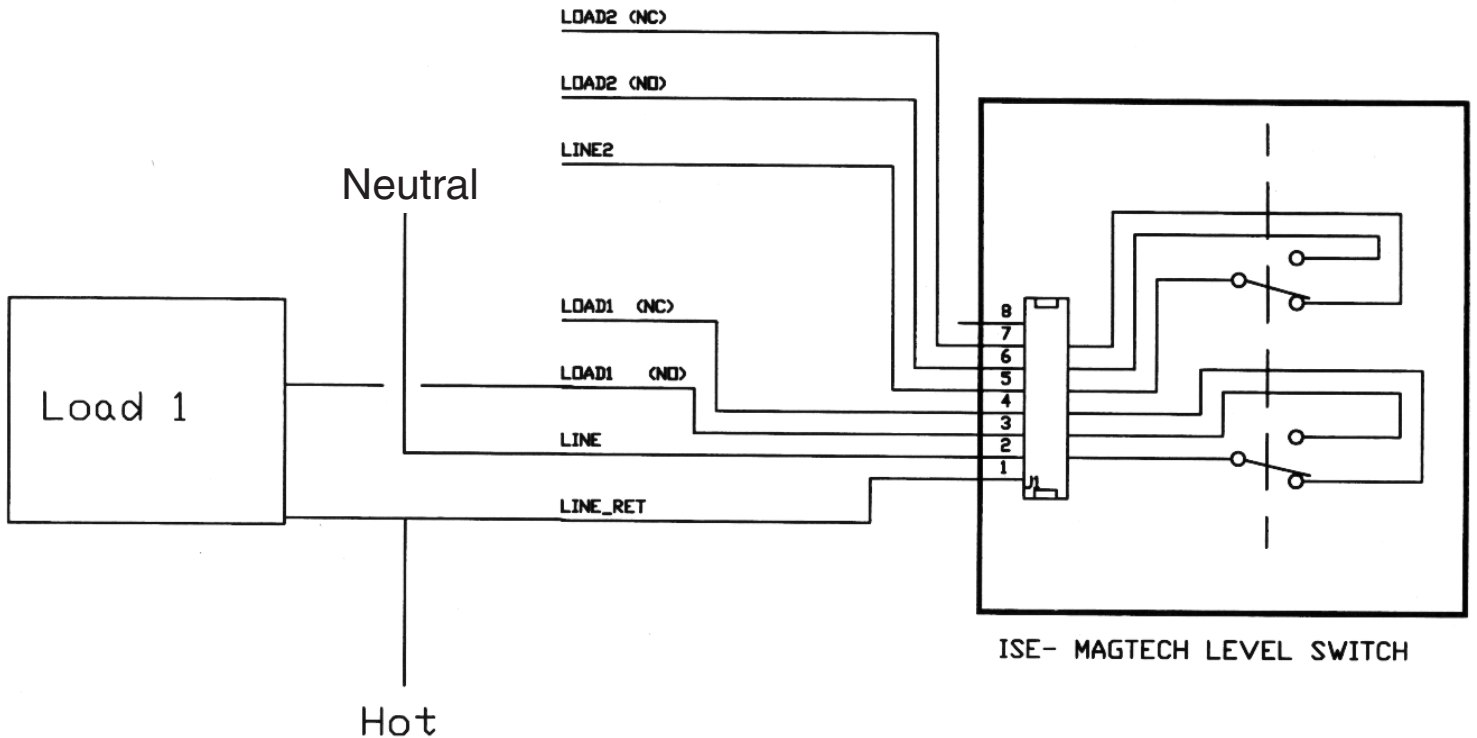

# GAGE MOUNT LEVEL SWITCHES (Cont.)

## PS-2 PNEUMATIC SWITCH

### PS-2 SPECIFICATIONS

Deadband	0.7 inch
Max. Temperature	300°F
Min. Temperature	0°F
Supply Pressure @ 70°F	15 - 100 psi
Supply Pressure @ 300°F (Dry, Filtered air or gas)	15 - 35 psi

Housing 316SS, Nema 4

### SWITCH OPERATION/MOUNTING

To mount the MLS Series Level Switch simply clamp it directly to the side of the level gage chamber using the adjustable pipe clamps provided. Alarm set points may be changed by simply loosening the clamps and sliding the switch to the desired alarm level.

After the switches are mounted and wired, they need to be set to the desired state for rising or falling level as noted previously. This is easily accomplished by either manually pushing the float or magnet past the highest switch, or filling the gage chamber with fluid until all switches are properly set.

PS-2 Mounting Diagram

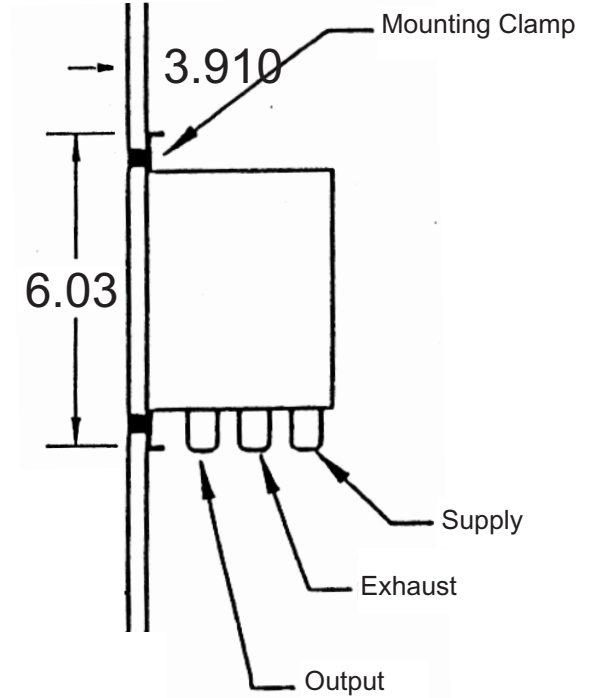

PS-2 Side view

Note: The switch should be mounted to the side of the gage as shown.

Note: PS-2 Switch is factory set for rising or falling level. This must be specified at time of order (Not field adjustable).

## LT-1/LT-2 2-WIRE TRANSMITTER

### DESCRIPTION

The LT-1 Level Transmitter is designed for use with the LG Series Level gage to provide a 4-20 mA control signal proportional to level. The transmitter consists of a sensor tube made up of a string of resistors and magnetically operated reed switches. There is a switch and resistor every ½ inch or ¼ inch along the length of the sensor tube.

The circuit board containing the resistors and switches may be the same length as the measured range or any portion thereof. The sensor circuit is enclosed in the stainless steel sensor tube. A threaded connection at the top of the tube is for mounting the transmitter housing. This housing is rated for Class 1, Division 1, Groups C & D hazardous areas. The LT-1 assembly may be made intrinsically safe by remote mounting of the transmitter in a safe area and operating the sensor through an approved safety barrier.

As the magnetic float inside the gage chamber rises with increasing fluid level, the switches close, thereby changing the resistance in the circuit. A two-wire transmitter converts this resistance change to a 4-20 mA current signal corresponding to fluid level. Resolution of the transmitter is ¼ or ½ inch (proportional to the spacing of the sensor switches).

### SPECIFICATIONS

SENSOR		TRANSMITTER
Length:	Up to 30 Feet	Output: 4-20 mA
Resolution:	½ Inch LT1-4/20-L-½ ¼ Inch LT1-4/20-L-¼	Power: 24 VDC Nominal Load: 750 Max
Sensor Tube:	304 Stainless Steel	
Operating Temp.:	to 500° F (Process Fluid)	
Approvals:	UL, CSA, Class 1 Div. 1 EXP.	

## LT1 CALIBRATION AND TROUBLESHOOTING

### USING FLOAT IN LEVEL CHAMBER

A quick check of the calibration is accomplished (with gage mounted) by draining the level chamber, checking the mechanical zero and then adjusting the sensor tube up or down until it reads 4 mA. Refill the gage chamber or fill it to a point that corresponds to the top range of the transmitter. The output should now read 20 mA.

If a complete calibration is to be performed, remove the transmitter and sensor tube from the level gage and follow the steps below:

1. Normal operation/Dip Switch 1,2,3 OFF 4 ON
2. Place magnet (float) at 0% (or 4mA mark) on sensor tube.
3. Adjust P2 to read 4mA on 24 VDC current loop.

4. Place magnet (float) at 100% (or 20mA mark) on sensor tube. Adjust P3 to read 20 mA on 24 VDC current Loop.
5. Repeat Steps 3 and 4 if necessary until transmitter is reading 4 mA to 20 mA.
6. Check 50% (12 mA mark).

Clamp the sensor back on the gage chamber loosely and slightly higher than it should be. Make sure the float in the chamber is in the zero position. Slowly adjust the sensor tube downward until the output goes to 4 mA. Tighten the clamps and the transmitter is calibrated. If there is a question about the output, compare it to the visual indication on the gage. One can also place a magnet against the sensor tube at a point above the gage float and the transmitter should give an output corresponding to that point, i.e.: if the gage is indicating 2 feet and a magnet is placed against the sensor at the 4 foot level then the output of the transmitter should jump to indicate 4 feet.

### CALIBRATION SWITCHES

The LT-1 is equipped with an onboard calibration circuit, which is factory set to simulate a level represented by a current loop output. The calibration switches can be set to produce a 4mA, 12mA and a 20mA output. The proper settings for the switches are displayed on page 20 and in the diagram. The LT-1 calibration circuit was designed for simple adjustments of the zero and span without having to shut down the process. It should be noted that the calibration switches bank of four DIP switches are adjusted to produce the appropriate current output based upon the length of the LT-1 sensor tubes, and are therefore not interchangeable with sensor tube of different lengths.

### CALIBRATION USING A VOLTMETER

Diagram shows a standard setup using a series resistor (250 ohms) to measure a voltage range of 1 to 5 volts. Connect a voltmeter in parallel with the 250 ohm resistor. Set the calibration switches to the 4 mA position and adjust P2 on the LT-1 circuit board until a reading of volt is displayed on the voltmeter. To adjust the span set the calibration switches to the 20 mA position and adjust P3 until a reading of 5 volts is displayed on the voltmeter. To verify that the midpoint is accurate and linear, place the calibration switches in the 12 mA position. The voltmeter should now display 3 volts.

### CALIBRATION USING AN AMMETER

Figure 1-1 shows a typical set up for measuring the output of a transmitter within the current loop. This particular procedure does not require the use of a resistor. Connect an ammeter in series with the power supply and the LT-1 transmitter. Set the range on the ammeter to read a level of 20 mA maximum. Set the calibration switches to the 4 mA position and adjust P2 on the LT-1 circuit board until a reading of 4 mA is displayed on the ammeter. Set the calibration switches to the 20 mA position and adjust P3 until a reading of 20 mA is displayed on the ammeter. Verify the midpoint by setting the calibration switches to the 12 mA position. The ammeter should display 12 mA.

## WIRING

- Term 1 + 4/20 mA
- Term 3 - 4/20 mA
- Term 4 Sensor
- Term 5 Sensor

## SENSOR TUBE ORIENTATION

The LT1 sensor tube comes pre-mounted to the level gage chamber. Transmitters with 1/4" resolution, as indicated on the back of the sensor tube, will have a black line located at the top of the sensor tube. If removed in the field it is VERY IMPORTANT to re-attach the tube with black line facing the float chamber. The black line is located at the top of the sensor tube and must be parallel with the chamber.

### Dip Switch Settings

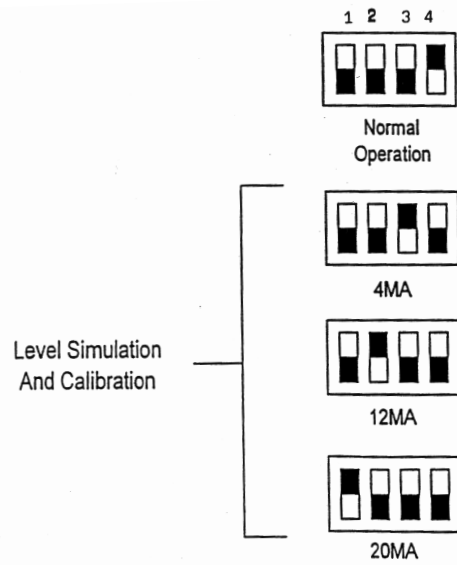
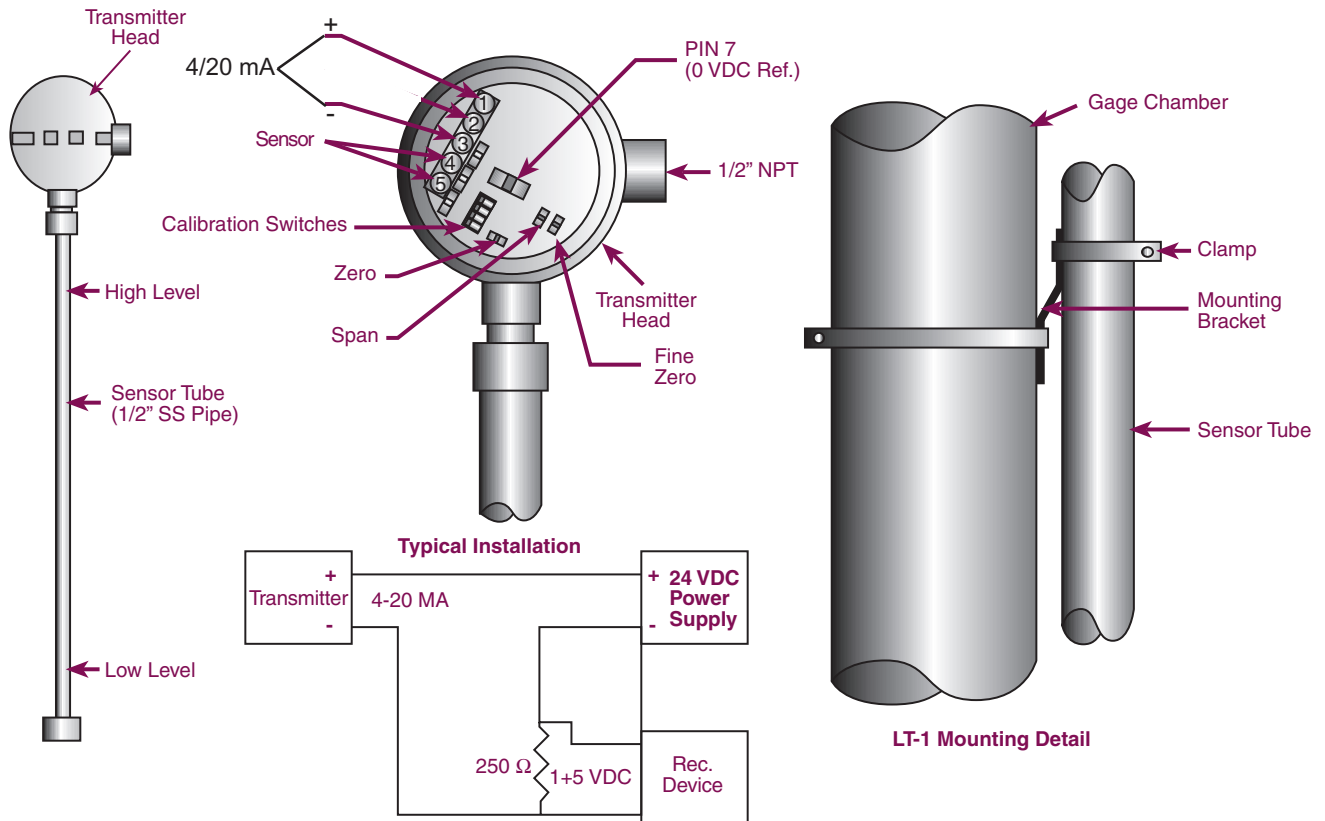

Figure 1-1

## LT-1 TRANSMITTER WIRING AND MOUNTING



**NOTE:** For information on insulating gages with transmitters see section on field insulation.

## Gage-Mounted LTM Magnetostrictive Transmitters

### Gage and Transmitter Installation

1. Visually inspect mag gage and transmitter installation to insure transmitter is positioned with the 4 mA and 20 mA labels directly adjacent to the process connections. Make sure transmitter is securely clamped and parallel to gage chamber.
2. Remove bottom flange and install float. Each float is clearly tagged with serial number of the mag gage and process parameters. Top of float is clearly marked "TOP" to insure float is in right side up.
3. Inspect bottom flange for proper gasket and spring. This spring protects float and keeps it from dropping below the bottom process connection. To determine proper spring length measure "A" dimension of gage. This is the length from the center of the bottom process connection to face of the bottom drain flange. Length of spring should be  
  
(“A” DIMENSION) (-) minus (Float Length + 2 inches)  
  
EXAMPLE: “A” Dimension is 14”, Float length is 12”, + 2” = 4”  
Spring Length.  
$$14 - 12 + 2 = 4” \text{ spring}$$
4. Float is properly installed if the bottom 2-3 flippers on gage indicator have flipped.

**NOTE: there is a top spring in the mag gage to protect float and prevent it from passing the top process connection. DO NOT REMOVE EITHER SPRING.**

### Transmitter Check-out and Calibration

NOTE: The LTM Series Transmitters are 24VDC Loop powered (2-wire) and require a minimum of 15 Volts at 20 mA.

1. Using a loop calibrator (HART compatible if LTM has HART) connect red wire from the LTM to positive lead of calibrator and white wire from LTM to negative lead of calibrator.
2. With float in the gage at 4mA, the output of the LTM should be 4mA. For units with HART connect the HART communicator to HART terminals on the LTM control board (see I/O manual for details). Upon power up, the HART Communicator should read the LRV (lower range value) or 0 inches at 4mA.
3. With float in the gage at 20mA, the output of the LTM should be 20mA. HART should also display URV (upper range value) or span length in inches at 20mA.
4. To insure complete functionality of gage and transmitter, fill the gage chamber with liquid and drain slowly to observe transmitter and gage are tracking properly.

5. If no float is present, or magnetic field is lost, HART Communicator will display:  
Generic Mode - “More Status Indicated, but Inaccessible.”  
Device Description - “Check Float”
6. For push-button calibration without using HART, or to change range consult the LTM instruction manual.

**Note: In service over 400 Deg F (204 C) Gages and Transmitters should be properly insulated with transmitter OUTSIDE the blanket. See LTM Transmitter Instruction Manual for details.**

### NOTE:

During the installation or calibration of the LTM level transmitter, the technician should be very careful not to move the magnet perpendicular to the sensor tube as this could leave magnetic indentation in the sensor wire. The LTM level transmitter has an inductor located inside the bulkhead of the sensor tube. During operation of the transmitter, this inductor emits a magnetic field as current passes through the sensor wire. If an external magnet or the float comes in contact with the bulkhead, this can cause magnetization of the coil, which means the coil is biased. In other words, the phase is reversed. If this occurs, the inductor should quickly recover. It may be manually reversed or de-magnetized very simply by “swiping” a magnet parallel to the bulkhead in an arching motion. For complete information regarding LTM Magnetostrictive Transmitters consult LTM I/O Manual.

## FIELD INSULATION OF GAGES WITH TRANSMITTERS

We strongly recommend that experienced MagTech personnel do any insulation of the magnetic level gages with externally mounted transmitters.

If Cryogenic “Hard Skin” cold service type insulation is required, it MUST be done at the factory due to the custom “Tube in Tube” design necessary for removal of the transmitter if needed.

If insulation is going to be done in the field, then the following guidelines MUST be followed:

1. Flexible type insulation jackets (NOT HARD SKIN) are required and must be installed around the Mag Gage chamber only. DO NOT cover the transmitter tube, as this may burn up the sensor and possibly the electronics.
2. After the insulation jacket is installed, the sensor tube must be re-mounted at its factory-preset distance from the Mag Gage chamber and must be parallel to the chamber as well. (Small cut-outs in the jacket are required to re-attach the transmitter properly)
3. Make sure the 4mA and 20mA marking's on the sensor tube are re-aligned at the centers of the process connections.

## TERMS AND CONDITIONS OF SALE

1. Unless otherwise stated, all quotations expire thirty (30) days from their date and may be modified or withdrawn by ISE-Magtech prior to any acceptance. All quotations and prices are subject to change without notice. Prices do not include any present or future sales, use, excise, value-added or similar taxes; and where applicable, such taxes shall be billed as a separate item and paid by Buyer.
2. Shipment of quoted material is subject to prior sale. Firm delivery will be established after receipt of purchase order. Shipping dates are not guaranteed, but if stated, are based upon best information then available. ISE-MagTech shall not be liable for failure to deliver or for delay in delivery or performance due to (a) a cause beyond its reasonable control or (b) an act of God, act or omission of Buyer, act of civil or military authority, governmental priority or other allocation or control, fire, strike, or other labor difficulty, riot or other civil disturbance.
3. Cancellation of an order is subject to acceptance by ISE-MagTech. Goods in process or in a completed state are subject to billing.
4. Payment terms are net thirty (30) days provided ISE-Magtech has extended credit to the Buyer or other arrangements have been made at the time of sale. Late payment of invoices may void product warranties. Buyer hereby acknowledges that any contract resulting from this quotation is a contract between the Buyer and ISE-Magtech and that payment of ISE-Magtech invoices is not subject to receipt of payment by Buyer from third party. Buyer hereby agrees to pay interest on past due amounts at 1½% per month, or the maximum non-usurious rate allowable by law, beginning on the thirty-first (31<sup>st</sup>) day after the date of the invoice and Buyer agrees to pay interest until the invoice is paid. Buyer also acknowledges and agrees that ISE-Magtech may revoke credit privileges and withhold shipment of goods as a result of non-payment or late payment of invoices. Packing and handling charges of \$20.00 will be added to each order that is over \$500.00. This is a standard charge to all customers and is not a freight charge.  
  
Should Buyer default in the payment of the outstanding account for monies that are deemed legitimately owed, then ISE-Magtech shall be entitled to incur expenses for the cost of collection and reasonable attorney's fees, which amount shall be added to the unpaid balance of Buyer's account and shall be due and owing from Buyer to ISE-Magtech.
5. No items will be accepted for return without the written permission of ISE-Magtech. Buyer hereby agrees to pay restocking charges that will be assessed by ISE-Magtech at the time of authorization of the return. All returned items will be subject to inspection and credit will be issued for any items deemed by ISE-Magtech to be in re-salable condition. Fitness for resale will be at the sole discretion of ISE-Magtech. Freight charges for returned items for credit shall be at Buyer's expense.
6. Unless explicitly stated in writing, all shipments will be FOB shipping point all applicable freight charges will be billed to the Buyer.
7. ISE-Magtech assumes no responsibility for goods meeting any job specifications or requirement unless specifically so stated in it written quotation.

ISE-Magtech's liability arising out of any sale of goods to Buyer is expressly limited to either (a) refund of the purchase price paid by

## TERMS AND CONDITIONS OF SALE (CONT.)

- Buyer for such goods (without interest), or (b) repair and /or replacement of such goods, at ISE-Magtech's election, and such remedies shall be exclusive and in lieu of all others. In no event shall ISE-Magtech be liable for indirect, special, incidental or consequential damages of any nature, including, but not limited to, personal injury or property damage. Buyer's recovery from ISE-Magtech for any claim shall not exceed the purchase price paid by Buyer for the goods, irrespective of the nature of the claim, whether in warranty, contract or otherwise.
9. This agreement and performance by the parties hereunder shall be construed in accordance with the laws of the State of Texas. If any provision or portion of this agreement is held to be invalid, illegal, unconscionable or unenforceable, the other provisions hereof shall not be affected.
  10. Buyer acknowledges and agrees that the terms and conditions set forth herein, and in the quotation, are hereby made an integral and binding part of any resulting contract or purchase order.

## WARRANTY

All MagTech products are warranted against defects in materials and workmanship for one year from date of shipment. The level gage chamber and process connections are guaranteed for the life of the tank or vessel to which it is attached. Floats are guaranteed for two years. MagTech will repair or replace at its discretion those products, which fail to perform as specified, with the following exceptions:

1. Products repaired or modified by persons that are not authorized by MagTech.
2. Products subjected to misuse, negligence or accidents.
3. Products that are connected, installed, or otherwise used in such a way not in strict accordance with manufacturer's instructions.

This warranty is in lieu of any other warranty expressed or implied by any party other than MagTech. Repairs and/or replacements shall be at the sole discretion of MagTech based on the terms and conditions of this warranty. Defective products shall be returned to the factory prepaid by the buyer after obtaining a Return Authorization Number from MagTech. All warranty repairs or replacements will be preformed at the factory in Houston. Surface return freight will be paid by MagTech. **Factory warrantys do not include field service. Field service warranty repairs will be at buyer's expense. Consult MagTech for field service rates.**

Any modifications to terms and conditions of this warranty will not be binding unless made in writing and signed by an authorized agent or official of MagTech.

NOTE: ALL MAGTECH GAGES SHOULD BE UNPACKED AND THOROUGHLY INSPECTED UPON RECEIPT. GAGES ARE SHIPPED FOB FACTORY AND ARE FULLY PROTECTED AGAINST DAMAGE OR LOSS DURING SHIPMENT. ANY CLAIMS FOR PARTS DAMAGED DURING SHIPMENT SHOULD BE SUBMITTED WITHIN 15 DAYS OF RECEIPT OF GOODS BY CUSTOMER.