

The smart idea for optimised tank measurement

The Honeywell Enraf SmartRadar FlexLine establishes new levels of precision and flexibility in tank inventory management. By combining wholly new software algorithms with Honeywell Enraf's internationally acclaimed planar antenna technology, SmartRadar FlexLine ensures the levels of precision demanded for custody transfer accuracy. In the most challenging circumstances, like dome roofs and on bad stilling wells, the SmartRadar Flexline maintains its ultra-high performance level. The Enhanced Performance Signal processing makes it in many cases possible to provide an accurate level reading even when a free space antenna is installed close to the tank shell. This could mean there is no need for a costly stilling well.

Technical specifications

Measuring specifications

Measuring range	: up to 75 m (246 ft)
Instrument accuracy	: Xtreme Precision SmartRadar ± 0.4 mm (0.016") * : High Precision SmartRadar ± 1 mm (0.04") * : Advanced Precision SmartRadar ± 3 mm (0.12") *
Measuring resolution	: 0.1 mm (0.001 ft)

Principles

Measuring principle	: FMCW / Synthesized Pulse Reflectometer
Signal processing	: Enhanced Performance Signal processing (EPS)
Operating frequency	: Xband (9.538 GHz to 10.561 GHz) R&TTE, FCC compliant

Mechanical

Dimensions	: See drawing opposite
Weight	: 10 kg excluding antenna and separator
Cable entries	: 3/4" NPT or M20

Environmental

Ambient temperature	: -40 °C to +65 °C (-40 °F to +149 °F)
Storage temperature	: -50 °C to +75 °C (-58 °F to +167 °F)
Protection class	: IP66 / IP67 according to EN 60529 (NEMA 4X)
Safety	: Explosionproof <ul style="list-style-type: none">- ATEX II 1/2 G Ex d IIB T6 or Ex d [ia] IIB T6 or Ex de IIB T6 or Ex de [ia] IIB T6- IEC Ex Zone 0/1 Ex d IIB T6 or Ex d [ia] IIB T6 or Ex de IIB T6 or Ex de [ia] IIB T6- Class I, Division 1, Groups C and D, acc. to ANSI / NFPA 70 (FM, CSA)

Materials

Instrument unit housing	: Aluminum alloy according to EN1706
Instrument unit finish	: Hard anodising according to MIL A8625-E Type III
O-rings	: NBR 70

Electrical

Power supply	: autoselect 65 Vac to 240 Vac (+10 % to -15 %) 50 / 60 Hz autoselect 24 Vdc to 65 Vdc (+10 % to -15 %)
Power rating	: Typical 15 W max. 23 W with options

Safety & approvals

ATEX, CE, IECEx, OIML, CB Scheme, FM, CSA, FCC, API, NMI, TÜV certified Overfill Protection

Options / communications

5 module slots available, for all type of interface solutions see Module sheets

Note:

*) Under reference conditions

Identification code

Pos 1 Device selection			
R	SmartRadar FlexLine		
Pos 2 Type of gauge			
X	Xtreme Performance, with local W&M approval and verification (specify National Metrology Institute) Including individual verification test report		
Y	Xtreme Performance		
H	High Performance, for custody transfer acc. to OIML R85, API 3.1B and ISO 4266-1		
I	High Performance, for custody transfer acc. to OIML R85, API 3.1B and ISO 4266-1 with Enraf test report		
A	Advanced Performance, for inventory control acc. to API 3.1B and ISO 4266-1		
U	Advanced Performance, for inventory control acc. to API 3.1B and ISO 4266-1 with Enraf test report		
Pos 3 Display			No. of terminals
			i.s.
			non i.s.
I	Including integrated SmartView display		
V	With IS terminal for connecting stand alone SmartView		4
B	With integrated SmartView display and IS terminal for connecting stand alone SmartView		4
Z	No display		
Pos 4 Data transmission *			
B	Bi-phase Mark, GPU protocol		2
G	EIA-232, GPU protocol		3
W	EIA-485, GPU protocol		3
Pos 5 I/O Options *			
-	None		
V	VITO temp. and/or water sensor interface		2
Q	HART input for HART communications		2
R	HART input for HART communications + HTMS (HIMS) density calculations		2
C	Hardware alarms (SPDT NO/NC) contact outputs (2x) 125 Vac, 0.5 A (110 Vdc, 0.3A)		4
N	Hardware alarms (SPDT NO/NC) contact outputs (2x) 250 Vac, 3 A (40 Vdc, 3A)		4
O	Hardware alarms (SPDT NO/NC) contact outputs (4x) combination of options C and N		8
Pos 6, 7, 8 Additional Data transmission and/or I/O Options *			
□	□	Select code from Pos. 4 and 5	Total: * *
□	□	Select code from Pos. 5 **	maximum sum of i.s. terminals is 10
□	□	Select code from Pos. 5 **	maximum sum of non-i.s. terminals is 15
Pos 9 Safety approvals			
A	ATEX / IEC Ex		
F	FM (only if pos. 10=C or M)		
C	CSA		
Pos 10 Cable entries			
S	Ex e terminal compartment with 4 cable entries (4xM20) (only if Pos 9 = A or C)		
E	Ex e terminal compartment extended to 6 cable entries (6xM20) (only if Pos 9 = A or C)		
C	3x 3/4" NPT		
M	2x M20		
Pos 11, 12, 13 Antenna version			
F 0 8	8" PAT, Free space		
W 0 6	6" x 12" WALP, Free space		
T 0 6	6" x 12" Hinged WALP, Free space (only if Pos 2 = A or U)		
F 0 6	6" PAT, Free space (only if Pos 2 = A or U)		
D 0 4	RoD, Free space (only if Pos 2 = A or U)		
S 0 6	6" PAT, Stilling well		
S 0 8	8" PAT, Stilling well		
S 1 0	10" PAT, Stilling well		
S 1 2	12" PAT, Stilling well		
H 0 4	4" Horn, High pressure		
Pos 14, 15 Stem length / Application type			
x x	0 mm (only if Pos 11 = D)		
0 5	50 mm (Not if Pos 11 = D, H, W or T)		
3 0	300 mm (Not if Pos 11 = D or H)		
5 0	500 mm (Not if Pos 11 = D or H)		
8 0	800 mm (Not if Pos 11 = D or H)		
B 1	Installation on 6" 300 lbs nozzle with 4" Schedule 10 stilling well (only if Pos 11 = H)		
B 4	Installation on 4" 300 lbs full bore ball valve (only if Pos 11 = H)		
N 1	Installation on 6" 300 lbs nozzle with 4" Schedule 10 stilling well including 1" full bore ball valve (only if Pos 11 = H)		
N 4	Installation on 4" 300 lbs Schedule 40 nozzle including 1" full bore ball valve (only if Pos 11 = H)		
R X I B V - - - A S F 0 8 3 0	Typical identification code		
R	Your identification code		

*) Add terminal count per choice

***) Max. 2 identical I/O options

Dimensional drawing

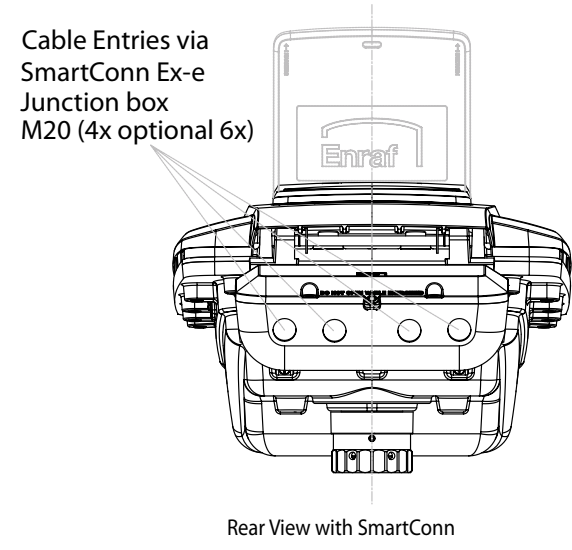
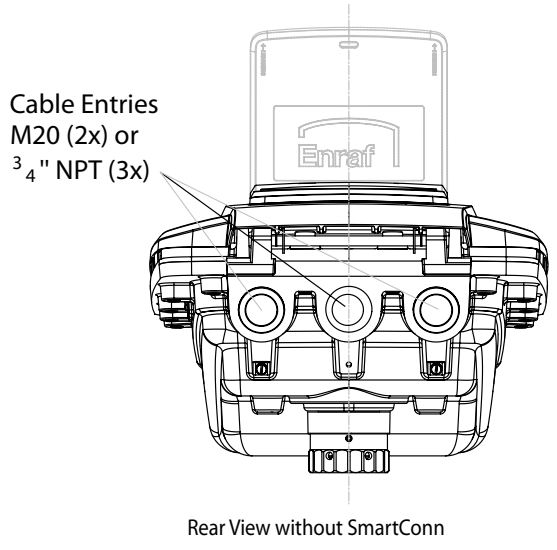
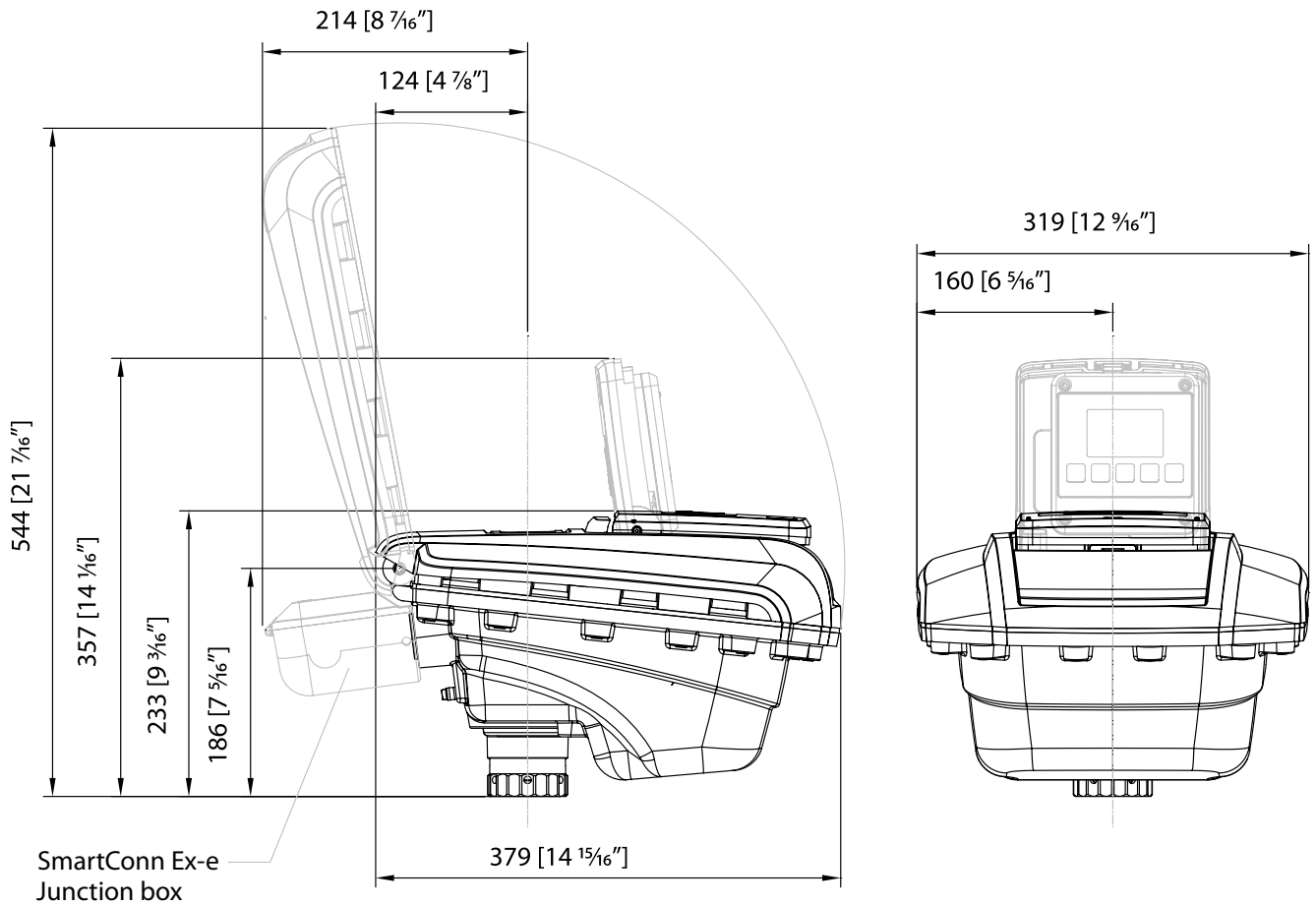

Dimensions in mm / inches

Honeywell Enraf

Delftechpark 39
2628 XJ Delft
The Netherlands
Tel: +31 (0)15-2701 100
www.honeywellenraf.com

